

*"Ere many generations pass, our machinery will be driven by power obtainable at any point in the universe...it is a mere question of time when men will succeed in attaching their machinery to the very wheelwork of nature."*

*- Nikola Tesla*

# FREE ENERGY PROJECTS 1

## COPYRIGHT AND DISCLAIMER

### Copyright

All text, graphics, the selection and arrangement thereof (unless otherwise noted) are Copyright © 1997-1998, Top Secret Publishing (TSP), 5025 N Central Ave #414, Phoenix, AZ 85012 USA. ALL RIGHTS RESERVED.

Some of the article contained in this report are considered Bonus articles, provided as a benefit to the reader. All Bonus articles are copyright their respective authors.

### Disclaimer

Top Secret Publishing is providing this report on an "as is" basis and makes no representations or warranties of any kind with respect to its contents. The articles contained herein are sold for informational purposes only and all local laws apply. Any use or misuse of this information is solely the responsibility of the purchaser. TSP disclaims all such representations and warranties, including for example warranties of merchantability and fitness for a particular purpose. In addition, TSP does not represent or warrant that the information in this report is accurate, complete or current. This information was gathered from sources believed to be reliable, but cannot be guaranteed insofar as they apply to any particular individual.

This report is sold with the understanding that the TSP is not engaged in rendering legal or accounting services. Questions relevant to the specific tax, legal, and accounting needs of the reader should be addressed to practicing members of those professions.

Neither TSP nor any of its directors, employees, other representatives or advertisers will be liable for damages arising out of or in connection with the use of this report. This is a comprehensive limitation of liability that applies to all damages of any kind, including (without limitation) compensatory, direct, indirect or consequential damages, loss of data, income or profit, loss of or damage to property and claims of third parties.

**Top Secret Publishing**  
**5025 N Central Ave #414, Phoenix, Arizona 85012**

**Fax: 425.977.7842**

**Internet: <http://secret-solutions.com>**

**Email: [info@secret-solutions.com](mailto:info@secret-solutions.com)**

**TABLE OF CONTENTS**

POWER FOR THE FUTURE.....	4
THE UNSCIENTIFIC SCIENTIFIC SYSTEM.....	9
FREE ENERGY FROM MAGNETISM.....	14
INSIGHTS INTO THE PROPRIETARY SYNDROME .....	17
HIGHTECH HISTORY.....	21
A CRITICAL REVIEW OF FREE ENERGY.....	27
THE STANDARD OIL TRUST .....	40
THE ROLE OF THE CIA IN THE GLOBAL OIL CONSPIRACY.....	68
SUPPRESSION OF FREE ENERGY DEVICES.....	81
ADVANCED ENERGY PROTOTYPE TESTING AND PREPARATION FOR COMMERCIALIZATION.....	93
GOVERNMENT INVOLVEMENT IN SUPPRESSED INVENTIONS .....	98
NON-CONVENTIONAL ENERGY PATENTS .....	112
FUEL ECONOMY PATENTS.....	117
ELECTROMAGNETIC OR IONIC PROPULSION SYSTEMS .....	121
PCV JAR PLANS.....	125
CHAIN REACTION.....	128
PRODUCING HYDROGEN AT 1.24 VOLTS.....	130
FUEL FROM WATER.....	132
A WATER-FUELLED CAR .....	138
FUEL FOR FREE - HYDROGEN GENERATOR.....	145

## POWER FOR THE FUTURE

**BY HAL FOX**

---

Magnetic motors that will run without input power, solid-state circuits that provide more power out than power input, mechanical perpetual motion machines, methods of tapping the ZPE, and nuclear reactions from charge clusters. These concepts have been recently presented in various media and conferences. Various inventions and theories abound. However, most of these concepts have yet to be demonstrated or replicated. A few of these devices have been actually demonstrated to work!

Funding and backing for commercialization are limited, scarce, and almost non-existent as is funding for research or development in these areas. The need to stop polluting the atmosphere by burning fossil fuels is evident. However, there are promising devices and systems! Among these are the works of living inventors and scientists that do show promise to become the power for the future. This paper discusses these concepts and issues a challenge to you!

### **The Need**

Fifty years ago, the newly paved lower road through vineyard, Utah had its annual spring migration of toads. The small streams were abundant with frogs. Today you can scarcely find a toad or a frog in the farms and pastures bordering the Utah lake. The demise of life forms sensitive to environmental changes is being reported now in many countries.

In 1979, the atmosphere in November in Beijing was full of smoke from homes and factories. Today in China over 20 new coal-burning power plants are in the planning or building stage and each will provide power production of ten to twenty megawatts and further pollute the atmosphere. Flying over Europe can be a lesson in how to pollute a continent. Missionaries assigned to Poland are cycled to only a one-or two-months stay in the worst cities due to health-degrading pollution. The Atlantic ocean is dying and this death on land and sea continues to spread.

Pollution can come from industrial chemicals, agricultural fertilizers, pesticides, but most of all it comes from the burning of fossil fuels in power plants, factories, homes, and transportation vehicles. It is absolutely clear that we need clean and abundant energy - now!

## **The Promises**

The readers of New Energy News and other newsletters, and the attendees at various new-energy conferences, have all heard about a variety of pending and promising new-energy devices and systems. Some of the more promising devices discussed in NEN include: the testatika machines of the Methernitha community in Switzerland, the Reed magnetic motor, the DePalma motor and n-machines, the Searl generator, the Sinclair generator, the Adams motor, the pap engine, the GEET engine, the Hamel generator, the Newman motor, the ROM generator, the Davis tidal turbine, the magnetic resonance (MRA) amplifier, Brown's nuclear battery, various cold fusion cells, the Zielinski discovery, the Aspden effect, the Rowe effect, Bearden's scalar energy fields, the Correa plasma system, shoulders' EV's, the Neal-Gleeson process, plasma-injected transmutation, etc. these are the exciting promises! Now - where are the delivered results and the actual devices that work repeatedly?

The devices that to date have really been publicly demonstrated and/or independently replicated are few. And they really do work! here are some of the successes: The Correa plasma device, certain cold fusion cells, milli-watt versions of the MRA, the Neal-Gleeson process, the Davis tidal turbine, and the use of shoulder's high-density charge clusters or plasma-injected transmutation.

The new-energy systems that we have expected to be commercialized and that have not yet been repeated, demonstrated or replicated are: the Swiss Testatika; commercial versions of the Pons-Fleischmann cold fusion reactors; commercial versions of over-unity magnetic motors; commercial versions of solid-state circuits; the Meyer water fuel cell; and brown's nuclear battery. many promising devices have been lost with the deaths of their inventors (e.g. Tesla, Moray, Henderschott, Papp, Russell, Sweet). Some devices are being held back until the inventor "gets enough money up-front" (e.g. Hyde, Mark). Several new devices in development were/are actively suppressed by the wanton destruction of the organization from greed or "outside" sources (e.g. Brown's nuclear battery, Becocrafat in Germany, etc.). Other promising devices seem to become instantly "classified" during the normal u.s. patent process and thus become "lost." If we want to actually develop and commercialize these devices, then clearly there is a better way to be doing it!

## **Died from Lack of Funding**

Many products have died, and are not currently under development, due to lack of supportive funding. Brown's nuclear battery must be included in this group. In addition, there is almost no funding for any cold fusion work within this country! Many promising approaches to cold fusion by various

investigators in the u.s. have been hampered by the grossly unfair and inaccurate old report of the ERAB subcommittee on cold fusion and the subsequent arrangements within the u.s. government and its agencies to prevent patents from being issued and to prevent doe funds from being granted to cold fusion projects.

Many projects have not secured funds due to the lack of scientific support. The current EM models now taught for electricity and magnetism do not allow for any over-unity device. The predominant belief that there is no energetic aether (nor any outside potential sources of additional energy) ensures that funds for tapping space energy will be hard to obtain (just as in tesla's time). The currently-accepted scientific dogma that low-energy nuclear reactions cannot exist is the basis for decisions against funding this type of research. The end result is that many promising projects have been abandoned because the inventor could not obtain funds through government or industry or private sources.

### **The Pursuit of Arcane Technology**

There have existed intellectual giants who have developed devices that were so important to the developers that their secrets were not revealed. Some organizations and individual groups are dedicated to discovering the secrets of the past from ancient societies, to Tesla, Keeley, Coler, Sparky Sweet, and others. This search can make for fun research and interesting discoveries. However, if we spent a similar amount of money and effort on understanding today's geniuses as we do on the past giants (e.g. Tesla), we would likely have already solved the world's energy problems.

### **The Support of Today's Geniuses**

In the "cold fusion" area, Martin Fleischmann and Stanley Pons are geniuses. They are also currently the only new-energy geniuses that have been adequately funded. Here is a partial (incomplete) list of genius-level work in the u.s. that should be adequately funded: Mitchell Swartz cold fusion work with light water and nickel; Randall Mills work with hydrogen gas and nickel; Bush and Eagleton's work on cold fusion and radioactive amelioration; Correa & Correa's work on plasmas; James Grigg's work with heat-producing pumps; Lambertson's solid-state work; Greg Hodowanec's work with mini-MRA type devices; the work of Ron Kovac et al., on plasma physics, Harold Aspden's work on high-efficiency motors; the Finsrud motor; the proven Davis tidal turbine; further investigation of the Rowe effect; the Neal-Gleeson process; Kenneth Shoulders' work with high-density charge clusters; plasma-injected transmutation effects; and low-energy transmutation of radioactive wastes.

Some of these scientists and inventors are today's geniuses. Others may not be classified as geniuses but their work is ingenious and deserves active support. Also, the independent testers and organizations that are available to provide independent and accurate verification of the operation of a device also deserve active support (e.g. Emmerich, Grotz, Hathaway, Puthoff, Rosenthal, etc.).

There are several resources supporting new-energy research and today's geniuses. The INE, Keelynet and other organizations have large and growing websites. Internationally, PACE offers a huge energy device database on CD. Other groups are also offering supportive services. Use them! Support each other! If you have any good information and you want to get it out to those who care about what you are doing, use these resources and ask for help! Ask! some researchers will want to remain very secretive, that is their right - great! - As long as the devices get developed and commercialized. Here is what all of us can do:

For researchers: make your research known, make your needs known, and ask for support.

For funders: make your interests known, ask about worthy inventors whom you can contact.

For incentives: Zenergy is offering \$100,000.00 for the demonstration of a new "free energy" machine.

For supporters: write articles and papers on what you think inventors and researchers need to do to get their ideas developed and commercialized. Tell them how to make their invention commercial. Use the websites and the publications! Greed is obviously not working. Cooperation, stock positions, and teamwork can work! Do it together!

### **The Challenge**

Consider the number of people who subscribe to the following U.S. publications (listed alphabetically): ANE newsletter, Cold Fusion, Cold Fusion Times, Electric Spacecraft Journal, Electrifying Times, Fusion Technology, Infinite Energy, New Energy News, Journal of New Energy, Keelynet BBS, PACE's Clean Energy Review, and Space Energy Journal. To a large extent, these subscribers represent those who are the most informed and the most interested in resolving the world's energy problems.

Here is the challenge: Each editor, each publication, and each subscriber is challenged to do the following:

1. Encourage the funding of new-energy technology by both government and private (such as rich individuals, organizations, educational or movie groups, non-profit donations from major companies and corporations, or even from venture capitalists).

2. Do something to expand the number of subscribers for each of these publications.
3. Form mutual fund groups dedicated to the funding of new-energy development.
4. Promote the allocation of grants by private charitable associations to support new-energy development. Write letters to government leaders urging them to support new energy development. Write letters to editors of publications that continue to treat new-energy devices as impossible.
5. Be pro-active (not reactive) and be accurate!

Join together to make things actually happen! Now! No one individual or organization can do everything. Everyone can do something! Together, we can do anything! Group actions are the most effective means to promote change. We should be aggressive, verbal warriors in support of worthy new technology and better life styles. The world is worth saving from further fossil-fuel pollution. We owe it to our children and our grandchildren to leave this world a better place for our having been here. If we don't make the change, who will? The forefathers of this country pledged their lives, their fortunes, and their sacred honor to make this a better country.

What will you pledge to make this a better world?



## THE UNSCIENTIFIC SCIENTIFIC SYSTEM

BY PAUL BROWN

The proper function of scientific education is not to provide skeptics who will continually challenge existing dogma, but rather to train highly competent puzzle solvers who will be content to work within the agreed framework of rules and theories - the current paradigm governing normal science (1). With this approach, the introduction of historical materials into science courses is often motivated by the desire to give the future scientist not only facts and technical skills, but also the correct attitude or general methodology. His teachers want him to respect the standards of impartiality, logical rigor, and experimental verification of hypotheses and to refrain from excessive theorizing about new or unexplained phenomena on the basis of metaphysical, mystical, or theological preconceptions (2). As the philosophers of science put it, he should be able to distinguish between the context of discovery and the context of justification- scientific hypothesis may come in an undisciplined way from the creative mind, but they must ultimately face the test of comparison with experiment and observation (3). Bell states, "as part of a general education all students should be aware of the nature of... hypothetical-deductive thought" as it has been developed in science (4).

Science textbooks generally place a strong emphasis on the experimental character of science. As Charles Kittle and his colleagues say (5);

*Through experimental science we have been able to learn all these facts about the natural world, triumphing over darkness and ignorance to classify the stars and to estimate their masses, composition, distances, velocities; to classify living species and to unravel their genetic relations. These great accomplishments of experimental science were achieved by men of many types. Most of these men had in common only a few things: they were honest and actually made the observations they recorded, and they published the results of their work in a form permitting others to duplicate the experiment or observations.*

Open-mindedness is one of the strongest of the scientists values. Another virtue often mentioned in textbooks is skepticism about established dogma. The scientist must be brave enough to question and criticize anything his teachers or his society may tell him, at the risk of ostracism, denial of financial support, or worse. Only in this way can a scientist hope to make a positive contribution to his subject. Sarton specifically stated that what may appear as error to one generation, might be seen as neglected truth by the next (6).

Most physicists feel the real world is too subtle for such bold attacks except by the greatest minds of the time, such as Einstein or Dirac. In the hands of a thousand others this approach has been limited by the inadequate distribution among men of sound insight. Thus teachers urge the student to assume realistically that he is not going to be an Einstein or Dirac, but merely another soldier in the ranks, who must learn the established rules for puzzle-solving within the framework of the current paradigm. His systematic labors will lead to the cumulative growth of normal science and may even, if he is lucky, uncover an anomaly that could be seized on by a rare genius to initiate a scientific revolution. But the good soldier should go no further since he will not know how to find or establish a new paradigm.

By adopting this approach, one implies that there are two kinds of scientists; the average scientists, who must obey the rules, and the genius, who will know when to break them.

According to Kuhn, scientists do not test theories by a hypothetical-deductive process at all: "Once it has achieved the status of a paradigm, a scientific theory is declared invalid only if an alternative candidate is available to take its place" (7). Thus, the framework of science sets the stage for resistance to scientific progress. Possibly, if we learn more about this resistance to scientific discovery, we shall know more also about the sources of acceptance, just as we know more about health when we successfully study disease (8).

Hemholtz, for example, made aware of such resistance by his own experience, commiserated with Faraday on "the fact that the greatest benefactors of mankind usually do not obtain a full reward during their lifetimes, and that new ideas need the more time for gaining general assent the more really original they are" (9). Max Plank is another who noticed resistance in general because he had experienced it himself, in regard to some new ideas on the second law of thermodynamics which he worked out in his doctoral dissertation submitted to the University of Munich in 1879, "None of my professors at the University had any understanding for its contents", says Plank, "I found no interest, let alone approval, even among the very physicists who were closely connected with the topic" (10).

A little self-examination tells us pretty easily how deeply rooted in the mind is the fear of the new. As Beveridge says, "there is in all of us the psychological tendency to resist new ideas" (11). Many of those who have noted resistance have been excessively embittered and moralistic. Oliver Heaviside exclaimed bitterly, when his important contributions to mathematical physics were ignored for 25 years, "Even men who are not Cambridge mathematicians deserve justice"(12). And Planck's reaction to the resistance he experienced was similar. "This experience", he said, "gave me also an opportunity to lean a new fact- a remarkable one, in my opinion; A new

scientific truth does not triumph by convincing its opponents and making them see the light, but rather because its opponents eventually die, and a new generation grows up that is familiar with it" (13).

Scientists suffer, along with the rest of us, from the ironies that evil sometimes comes from good, that one noble vision may exclude another, and that good scientific ideas occasionally obstruct the introduction of better ones. Because of their substantive conceptions and theories, scientists sometimes miss discoveries that are literally right before their eyes.

One methodological source of resistance is the tendency of scientists to think in terms of established models, indeed to reject propositions just because they can not be put in the form of some model. Ampere's theory of magnetic currents, for example, was resisted by Joseph Henry and others because they did not see how it could be fitted into the Newtonian mechanical model (14). Thus, models, while usually extremely helpful in science, can also be a source of blindness. Scientists positions on the usefulness of mathematics at the Jesuit Gymnasium in Cologne made little impression upon the more noted scientists of the German universities.

Specialization concentrates and focuses the requisite knowledge and skill where they are needed. But occasionally the negative aspect of specialization shows itself, and innovative outsiders to a field of specialization are resisted by the insiders.

Sometimes men of higher professional standing sit in judgment on lesser figures before publication and prevent a discovery's getting into print. Scientific publications are indispensable for communications in science. But occasionally, when organizations or publications are incompetently staffed and run, they may serve as another social source of resistance to innovation in science.

The older resist the younger in science is another pattern that has often been noted by scientists themselves and by those who study science as a social phenomenon. But this is not always so, and the older workers in science are often the most ardent champions of innovation.

As men in society, scientists are sometimes the agents, sometimes the objects, of resistance to their own discoveries (8). Galton says, "a new science can not depend on a welcome from the followers of the older ones"(15).

There is sometimes a tendency, when such resistance is noted, to exaggerate the extent to meet with opposition from his fellow scientists. And Trotter, for example, goes overboard by saying, "the reception of new ideas tends always to be grudging or hostile... Apart from the happy few whose work has already great prestige or lies in fields that are being actively expanded at the moment, discoverers of new truths always find their ideas resisted"(16).

However, one must not forget that not all men are honest or sincere. Experimental results have been twisted to support false doctrines. Hence, scientists can on occasion justify their skepticism as fraudulent activities do occur in the scientific world (17). From Westfall's article on Newton (18); "If the Principia established the quantitative pattern of modern science, it equally suggested a less sublime truth-that no one can manipulate the fudge factor quite so effectively as the master mathematician himself".

In conclusion, this author would say that claims of resistance are justifiable. Yet, it would appear that progress is made in spite of "science" in general. Thus, generally speaking, for the new to be readily accepted it must be better, easier, and prettier than the old. Any truth that does not meet these conditions must face the Plank axiom as he stated that new theories rarely get accepted by rational persuasion of the opponents-one simply has to wait until the opponents die out (19).

### **Bibliography**

1. T. Kuhn, "Scientific Creativity" (Wiley, N.Y. 1963)
2. S. Brush, "Should the History of Science be Rated x?", *Science*, Vol. 183, pp. 1164-1172 (March 22, 1974)
3. H. Reichenbach, "Experience and Prediction" (Univ. of Chicago Press, Chicago, ILL, 1938)
4. D. Bell, "The Reforming of General Education" (Anchor, N.Y. 1968)
5. C. Kittel, W. Knight, M. Ruderman, "The Berkeley Physics Course" (McGraw Hill, N.Y. 1962)
6. G. Sarton, "The Life of Science", (Schuman, N.Y. 1948)
7. T. Kuhn, "The Structure of Scientific Revolutions" (Univ. of Chicago Press, Chicago, ILL. 1970)
8. B. Barber, "Resistance by Scientist to Scientific Discovery", *Science*, Vol. 134 pp. 596-602, (Sept. 1, 1961)
9. R. Murray, "Science and Scientists in the Nineteenth Century" (Sheldon, London 1825)
10. M. Plank, "Scientific Autobiography" (Philosophical Library, N.Y. 1949)
11. W. Beveridge, "The Art of Scientific Investigation" (Random House, N.Y. 1959)
12. H. Levy, "Universe of Science" (Century, N.Y. 1933)
13. see ref. #10
14. T. Coulson, "Joseph Henry: His Life and Work" (Princeton Univ, Press, Princeton, N.J., 1950)
15. *Biometrika*, Vol. 1, pp. 7 (1901-1902)

16. W. Trotter, "Collected Papers" (Humphrey Milford, London, 1941)
17. Science Digest editor, "An Unscientific Phenomenon: Fraud Grows in Laboratories" Science Digest, June 1977, pp. 38-40
18. R. Westfall, Science Vol.179, pp. 751, 1973
19. M. Planck, "Philosophy of Physics" (Norton, N.Y. 1936)

## FREE ENERGY FROM MAGNETISM

Most people believe that it is impossible to build a motor run solely by magnets. But try to tell that to people like Howard Johnson who spent six years fighting the patent office to accept the reality of his magnet motor. They finally granted him U.S. Patent 4,151,431. And there are dozens of other magnet motor patents.

Engineers at Hitachi Magnetics Corporation have come right and told us that a motor run by magnets is feasible and logical, but the politics of the matter make it impossible for them to pursue developing a magnet motor or any device that would compete with the energy cartels. The obstacles to free energy are the big banks who own the energy industries.

Many achievements in developing free energy from magnetism have occurred in obscure basement workshops all over the country. Many of these achievements have remained the secret of the inventor, who being afraid of reprisal from the establishment did not share this technology.

The following information comes from Hitachi and other researchers:

"The magnet that lifts a pound today, if the load (on it) is gradually increased day-by-day, will lift double the amount in time. Whence comes this energy? Keely teaches that it comes from sympathetic association with one of the triune currents of the polar stream, and that its energy increases as long as sympathetic flows last, which is through eternity." (from the book "Keely and His Discoveries", by Clara B. Moore, 1983)

In developing a theoretical basis for self-powered magnetic motors, it will be necessary to examine some of the elementary observations of magnets.

1. Two permanent magnets can either attract or repel depending on the arrangement of the magnetic poles.
2. Two magnets repel further than they attract because of friction and inertia.
3. Most of our energy comes directly or indirectly from the electromagnetic energy of the sun, e.g., photosynthesis and water cycles of ocean to water vapor to rain/snow to ocean.
4. Magnetic energy "travels" between the poles at the speed of light. (Some researchers claim it is faster.)
5. Permanent magnets and ferrous metals are attractive only. Attraction is an inverse square force.
6. Two permanent magnets on both sides of an iron shield are attracted to the shield and only weakly to each other at close proximity to the shield.

7. Magnetic energy can be shielded, e.g., by placing a piece of iron between the magnet and the object it is attracting.

8. The sliding or perpendicular force of a keeper (e.g., the shield) is much less than the force in the direction of the field to remove the keeper.

9. Most of the magnetic energy is concentrated at the poles of the magnet. You can prove this by sprinkling iron filings around a magnet and seeing where the greatest concentrations of filings fall. This will give you a "picture" of the magnetic field.

10. A permanent magnet loses little strength unless dropped or heated. Heating, etc., mis-aligns the magnetic elements (domains) within a magnet.

11. If a weight lifted by a permanent magnet is slowly increased, the lifting (or pulling) power of the magnet will be increased up to the point where all the magnetic domains in the magnet are aligned in the same direction.

12. Using magnets for repelling tend to weaken them as it causes misalignment of the magnetic domains.

13. A magnetic material between two magnets will always be attracted to the stronger magnet.

By using some of the above magnetic principles in a mechanical arrangement, it is possible to "convert" the magnetic energy stored in permanent magnets into useable mechanical energy without the use of electrical energy, i.e., direct conversion of magnetism to mechanical energy.

According to modern magnetic theory a magnet motor would soon run down as the energy stored in the magnetic field would be used up driving the flywheel arrangement. However, the only way a magnet is "used up" is if it gets demagnetized by dropping, heating, or another magnetic field, or using an AC electrical demagnetizer.

If the magnetic field of a magnet is actually part of the magnetic field of the earth, then there can be no depletion.

Magnetic energy is not created. It is either stored in the permanent magnet or in the surrounding space. It can not be used up or destroyed.

Many magnetic materials are available. Knowledge and careful analysis is needed to make the right choice.

Only when there is a change in the balance of internal energies is energy released or absorbed by the permanent magnet.

In addition to design parameters, physical characteristics and environment must be carefully considered in the application of permanent magnets.

In development of properties, in design analysis, and in quality control of a particular permanent magnet, component-measurements are vital.

Changing the state of magnetization is an important factor in working with today's high coercive force permanent magnet materials.

It could be that the Hubbard Generating System has already made magnet motors obsolete. Whatever the case, it is obvious that free energy will be developed by individual effort since it is painstakingly clear that neither big business or big government will act in the best interests of the citizenry.



## **INSIGHTS INTO THE PROPRIETARY SYNDROME**

**BY KEN MACNEIL**

### **CADAKE INDUSTRIES**

---

To give you some background on myself, I have been interested in the energy situation since I can remember. I have built all kinds of devices, solar energy panels, windmills, photovoltaic arrays, flywheel devices, and also carburetors of which I will talk on Sunday. In my background I am an accomplished tool and diemaker, moldmaker, been involved in Design Engineering for the past 12 years, primarily in the automation area.

My first real involvement with other people in this alternate energy area was at the Toronto Symposium in 1981 where I met George Hathaway as well as over 100 other people that believe in the impossible according to orthodox science. Since that time I have made myself aware of just about everything that is happening in this field, and believe me there are some really fantastic things going on. The rediscovery of some of the technology that was lost in the past is finally coming to realization, for instance the Tesla technology, the Hubbard device, the Moray approach to tapping into the free energy supply that we're sitting in without even knowing it.

A friend of mine gave me a real insight possibly without even knowing it. He said the problem could only be solved by just considering the problem of weighing a glass of water at 500 feet under water. Here you are under water with a glass of water: how do you weigh it???

The analogy is the same for us. Here we sit in the vastness of the cosmos on top of one of the biggest magnets known to us and we are like the glass of water. We are in the vast ocean of energy. Look around us and watch just the weather for instance, the next thunderstorm, think of all the electrical potential being wasted. That energy is there; it is very real.

Tom Bearden, one of our upcoming speakers, may have illustrated it quite well by the bird sitting on top of the wire with 13,000 volts going through it. We all know that it could kill him but it doesn't. I am positive that within this group will be the ways and means for making the energy situation of the future change.

Now to the other side of this coin. Why has not this technology been allowed to become established? We have to look at the 'profit motive' involved. If we have free energy, how will they charge for it? What will happen to the billions of dollars that the utilities and oil companies and the

government backing these establishments do if we can give the people independence from the chains of having to pay for energy?

One question that has been uppermost in my mind for the last year has been the rhetoric given by our elected representatives about the energy situation and the amount of money given to small researchers who could possibly give us a viable approach to becoming energy independent. Who gets the government money?? Let me get a little audience participation in the question. How many of you have all the money you need for research in the energy area? Everyone who has please stand!!!! Now let me mention a few of the names of the companies that get the money. See if you recognize them: Exxon, Gulf Oil, General Electric, Westinghouse, TRW, Exide Storage Battery, all manufacturers or producers of fossil fuel products.

We need to get away from the fossil fuels for the future and get into something that can indeed give us a future because we are rapidly depleting not only our natural resources but our air and water. All because of burning fossil fuels. We fund our universities and colleges in the most directed of ways. If you want to explore the possibilities in some of the more esoteric areas, for instance the ones you will be hearing about in the next three days, there is no money for that. WHY??? Because of the possibility that we might succeed. What would our government do if all the American people could go back and forth to work, heat their homes, run their businesses without paying taxes on gas and oil?

Consider the fact that all of the gas stations would go out of business or would have to find other ways of making money. Many complimentary businesses would also fold. But alas, this is America. What are we here for??? To perpetuate Big Business, Big Government, or to advance toward the future, not expending all of our natural resources but to save them to make the goods of the future. Coal and oil both can be used for making all kinds of things besides fuels; the list is endless.

It is my feeling that the technology may be already here and may have been shown to the government. It even may have been introduced to our patent office and turned down. Because as you know, there is no such thing as a perpetual motion device. And I agree with the premise because forever is a long time.

But there are surely some of the devices or parts thereof that have been introduced to the government or to big business in the past which have been shelved. Tesla's transmission device is a classic illustration probably best known to this group. What happened is that they removed the money from him to do his research and effectively stifled this remarkable man. How many other times has it happened to someone not so well known?

At this moment, there are over 3,000 devices or applications in the patent office that have been branded as security or put under wraps by the secrecy order, Title 35, U.S. Code (1952) Sections 181-188.

What is security? How is it defined? I have had many inventors or other scientists tell me that they did not want to discuss their invention with me or others because they might lose it to us or we might tell someone else before they got it onto the market. Believe me, it won't get there by going through the patent process. It is my feeling that if such a device were introduced at this level, then it would be put under the Secrecy Act. I don't know that I am correct in this assumption. But I cannot imagine a government like ours wanting to commit financial suicide. So what better way than to brand something as a secret?

I would like to read the Secrecy Order to you so that you may better understand my concern. Please pay close attention. I think it is very important. To you or anyone!!! Consider your receiving this:

### **SECRECY ORDER**

***(Title 35, United States Code (1952), sections 181-188)***

*NOTICE: To the applicant above named, his heirs, and any and all of his assignees, attorneys and agents, hereinafter designated principals:*

*You are hereby notified that your application as above identified has been found to contain subject matter, the unauthorized disclosure of which might be detrimental to the national security, and you are ordered in nowise to publish or disclose the invention or any material information with respect thereto, including hitherto unpublished details of the subject matter of said application, in any way to any person not cognizant of the invention prior to the date of the order, including any employee of the principals, but to keep the same secret except by written consent first obtained of the Commissioner of Patents, under the penalties of 35 U.S.C. (1952) 182, 186.*

*Any other application already filed or hereafter filed which contains any significant part of the subject matter of the above identified application falls within the scope of this order. If such other application does not stand under a security order, it and the common subject matter should be brought to the attention of the Security Group, Licensing and Review, Patent Office.*

*If, prior to the issuance of the secrecy order, any significant part of the subject matter has been revealed to any person, the principals shall promptly inform such person of the secrecy order and the penalties for improper disclosure. However, if such part of the subject matter was disclosed to any person in a foreign country or foreign national in the U.S., the principals shall not inform such person of the secrecy order, but instead shall promptly furnish to the Commissioner of Patents the following information to the extent*

*not already furnished: date of disclosure; name and address of the disclosee; identification of such part; and any authorization by a U.S. government agency to export such part. If the subject matter is included in any foreign patent application, or patent, this should be identified. The principals shall comply with any related instructions of the Commissioner.*

*This order should not be construed in any way to mean that the Government has adopted or contemplates adoption of the alleged invention disclosed in this application; nor is it any indication of the value of such invention.*

It is my feeling that something on the order of a so-called 'free energy device' would receive this treatment. My only approach would be to go to the public domain. That is, get the information or the device out there to enough people that they could not stop you. This group looks like the best group to give this information to. Hopefully it will forthcoming in the next three days.

**Transcribed from: PROCEEDINGS; The Second International Symposium on Non-Conventional Energy Technology, pp 125-126.**

## HIGHTECH HISTORY

Stan Deyo was one of many Air Force cadets during the 1960's who dreamed of serving his country as an Air Force pilot. That was, until Deyo learned that something strange was going on in the Air Force Academy where he was stationed.

"Because of what he discovered while an unwilling 'guinea pig' in certain experiments that were secretly being conducted by a covert organization working within the military, Stan Deyo had to flee the United States for a new home half way around the world. Running as far as he could, the bearded scientist ended up in Perth, Australia, where he surfaced to tell his incredible saga of a conspiracy so sinister that it doesn't seem possible that something like this could actually transpire in the birthplace of George Washington, Abe Lincoln or John F. Kennedy.

Deyo had enlisted into the United States Air Force and was sent for special training to the highly prestigious Air Force Academy located in Colorado Springs, Colorado.

"...We were the elite from all over America, especially selected for a secret purpose we knew nothing about," he told PEOPLE MAGAZINE, an Australia weekly news magazine not to be confused with the celebrity profile magazine of the same name published in the U.S.

"They got control of our minds when we were asleep and fed us the most advanced physics for months on end. Then some of us began to realize something was happening to our minds and we rebelled.

"After two years, they failed the entire class--180 of us. We knew too much. I'm speaking out now because I believe the world should know what they are up to, as well as for my own protection."

As Deyo explains it, the Sixties were a turbulent period even as far as the U.S. government was concerned. For some unexplainable reason, Stan Deyo found himself along with his classmates in the middle of an "intelligence war" between the FBI and the CIA, with the CIA bound and determined to keep the lid on a brand new form of technology directly related to UFOs.

The CIA in conjunction with military-industrial "big business" has for a period of several years been in collusion, Deyo alleges, on findings that center around the development of a type of disk or saucer-shaped, antigravity machine that originated out of 'alien' technology. According to Deyo's scenario, the U.S. is worried that sooner or later they will run out of conventional fuel sources and that the 'elite' and powerful will need a revolutionary technology in order to survive, and no doubt maintain their control

over the populations of the earth. So they contacted General Electric, Sperry Rand and Bell Aircraft to spearhead a drive to develop this new technology, which can whirl a disc-like craft through interplanetary space at thousands of miles a second using the minds of the craft's crew members to navigate the Earth-made UFOs. This is where Deyo's training was supposedly to come in handy. Because of his intelligence level, he was to be made one of the ship's pilots as soon as his mental capabilities had been 'stretched' through hypnosis and an advanced form of electronic 'mind control'.

Anonymous deep-level 'Intelligence' insider 'Commander X', while referring to Stan Deyo's experiences, stated:

"...One of the most astounding things Deyo said--and this was almost ten years ago (i.e. around the late 1970's and early '80's - Branton)--was that he felt one of the staunchest supporters of this radically new anti-gravity technology was none other than the late William P. Lear--John Lear's father!

"At the time, Lear Sr. was quoted by the Associated Press as having said: 'I can't help but feel flying saucers are real, because of numerous manifestations over long periods of time with many simultaneous observations by reliable observers.'--And this is the clincher: 'THERE ARE NOW SERIOUS EFFORTS IN PROGRESS TO PROVE THE EXISTENCE OF ANTI-GRAVITATIONAL FORCES AND TO CONVERT ATOMIC ENERGY DIRECTLY TO ELECTRICITY...'

Commander X continues: "For those who hold suspicions that John Lear might--at least sometimes--be responsible for dealing from the 'bottom of the deck'--providing as much in the way as 'disinformation' as valid 'information'--we can't help but theorize about the significance of the above quote attributed to his father, and the possibility that some of what John Lear is telling us is meant to steer our attention toward 'aliens', rather than look right under our very noses at an Earthly technology that may be advanced beyond what we are currently taught is achievable through modern day science.

"We wonder if perhaps there isn't to be found substantiation behind the rumor that Lear Aircraft Company (a firm that John's dad founded) is directly involved in some sort of research and development project(s) involving anti-gravity and the manufacturing of UFOs made right here on Earth.

"One possible scenario is that John Lear found out about this Top Secret project--perhaps while eavesdropping--and this is his way of 'spilling the beans' without implicating his father or anyone else as the source."

In 1990, researcher Val Valerian released a peculiar document which was sent to him by another researcher. The document is actually a list of several military personnel; however, the strange thing about this document was the title-heading.

Some researchers believe that the deepest levels of the Government are involved in an on-going 'covert space program' utilizing some very remarkable aerospace and propulsion technologies. However, the very nature of this program, the clandestine (and possibly illegal) means by which it is funded, as well as possibly the means by which they came across this 'technology', has apparently led the 'Secret' Government into keeping these activities one of the world's top secrets, and apparently they have enforced this cover-up with 'deadly force'. But perhaps one of the most important reasons for the secrecy is the allegations that SOME groups within the secret government have allegedly in the face of 'superior alien technology', in a sense 'surrendered' to a malevolent alien race and have become their 'agents' on earth.

Is it also possible, as many researchers and prominent military, government and industrial personnel are actually confirming, that the 'secret government' is utilizing this advanced super-technology which they have hidden from the public, to carry out a clandestine space program involving not only manned flights to the moon, but also involving manned BASES on the moon and, some claim, Mars as well? There appears to be enough evidence mounting to cause the public to at least consider these claims. Actually, if one carefully examines all of the various claims and how they merge together, and if one studies the various theories and arguments concerning Einstein's 'unified field' theory and the apparent underlying connection between electromagnetism and gravity waves, etc., such a scenario would not be outside the realm of possibility.

The document referred to contains in the title heading both the terms 'Starfleet International' and 'United Federated Planets'. Why would such a statement appear on a military document? Could it be that, although perhaps somewhat presumptuously, a secret group of 'astronauts' constantly travel back and forth from ultra secret bases on or below the earth, the moon, and mars; and have in anticipation of an ever-growing interplanetary network named this organization 'Starfleet International' and/or the 'United Federated Planets'?

Val Valerian gives the following 'introduction' and story behind the document:

"...Researcher George Andrews forwarded this puzzle to us. From the introduction, it might seem that this thing was complete bunk. There it might have stayed, except that WE TRACED 11 PEOPLE ON THE LIST TO ACTUALLY BEING IN THE MILITARY. What does it mean?"

The following introduction is given by George Andrews: "A friend who wishes to remain anonymous, who lives in a large city, recently woke about 3 A.M. with a strong but apparently irrational impulse to get dressed and to go to an all-night photostat place. As she was entering, she noticed a man dressed in a Navy officers uniform who was just leaving, who threw some papers into

the trash barrel near the door. She made her copies and was about to leave and had another impulse to retrieve what the Navy officer had thrown away. She came up with these pages. Under normal circumstances, the news that the United States Navy has a flying disk named the U.S.S. Excalibur (and U.S.S. Concord? - Branton), operated by a crew of four, would be cause for celebration... however (unless) this achievement is the result of the collaboration of the 'Greys'..." Andrews goes on to suggest that they might, because of their collaboration with the 'Greys', be forced to take part in offensive attacks against the 'Blonds', who have allegedly had ancient conflict with the Greys.

The introduction goes on to state that those names which appear with an (x), are actually people that are in the military. Take special note of names like Ferguson, Caskey, Taylor, Burrall, Stevens, and Miller which are repeated more than once. Possible signs of Nepotism?

George Andrews suspects that 'Starfleet International' consists of human-military personnel only, while the 'United Federated Planets' may somehow tie-in with the non-human 'entities' such as the 'Serpent Race' or the 'Greys'.

PEA Research (105 Serra Way., Ste. 176., Milpitas, CA. 95035) made the following comments in one of their 'Files' (collections of large amounts of documents, research and other informations related to UFO's):

*"...Ramifications of MJ-12.*

*"If the U.S.A.F. test-flew a disk and was successful, what's to prevent them from using the same saucer to transport men and materials to the moon and mars? They would also be in a position to exploit the archeological artifacts of the pyramids and sphinx in the valley of Illysium on Mars. Also they could recover artifacts of previous races on the surface of the moon. With the aid of NASA satellites they could map and mine the rare earth (Moon,Mars) minerals at the expense of the tax payers while at the same time claim that we have nothing better in our technology than space shuttles (rocket power).*

*"In the Canadian Geomagnetic project was successful with their free-energy geomagnetic motor, then why haven't we seen free-energy engines for the home and auto instead of hearing about oil shortages?*

*"If the President of the USA is allowed only certain appointed staff by the Constitution and Congress - are the members of MJ-12 outside of the limits of the Constitution or did Congress give the President the power to set up a Secret Government (non-elected) without the public right to vote on this choice of the governing of the various military and non-military branches of the united states?*

*"When the MJ-12 use non-appropriated funds for their Secret operations are they using money from the Black Budget? If so, when did we cast a vote stating that ANY branch of the Government can use the taxpayers money without giving an account or being held accountable for it?*



*"When MJ-12 refuse to grant FOIA requests because of National Security reasons, is it because the USA won't be secure against foreign earthly powers, alien powers or against the wrath of a misled and deceived United States public (the Voters)?*

*"Can laws be passed to Guarantee that various branches of the Government will be held accountable for shredding of classified documents? How about passing laws to guarantee stiff jail sentences for underlings (secretaries, lower rank personnel) that carry out the command to shred confidential files?*

*"If the top of the mountain is corrupt, what about the foundation that was later raised under it. If a Secret Government is illegal, what about all of the secret projects it started and maintains control of? It's one thing to classify advances in technology as SECRET, but it's quite different to classify non-elected government as SECRET. When that nonaccountable Government (nonaccountable by reason of being SECRET) passes military laws that affect all branches of Government (military and non-military) are the laws legal or non Constitutional?*

*"If the JMP (Justice for Military Personnel) letter is true, are the actions of the CIA legal as used AGAINST citizens of the USA? Isn't the purpose of the CIA to protect citizens AGAINST foreign threats?*

*"If the MIBS exist according to the documents, what has happened to the Conscience of the Military Personnel that carry out false ID missions against private citizens? Why are Military Personnel carrying out higher up orders to impersonate branches of Government they neither represent or have Rank in? Is this patriotism or blindness?"*

In June of 1992, Associated Press Writer Ike Flores wrote the following in an article titled 'COLD FUSION MAY STIR SCIENTIFIC REACTION'. One might wonder if anything will come of this 'discovery', or if the multi-billion-dollar oil barons (whose very livelihoods would be threatened by such 'cheap' energy) will get to him first? Some accounts state that these power-mongers have crushed the inventions and inventors of 'free energy' magnetic, etc., devices in the past, and that they might attempt to do so in the future:

*"ORLANDO, Fla. -- An Orlando scientist awaits the reaction of his colleagues worldwide to an announcement that he's developed a laboratory cold fusion process that can be repeated on demand.*

*"Dr. Nelson Ying, a nuclear physicist, announced Friday that he is getting up to 100,000 TIMES more energy from a tabletop apparatus than he applies to it, and that he can repeat the procedure at will.*

*"A workable cold fusion process -- that can be used to produce cheap electric power -- has been touted as a solution to the world's energy problems.*

*"He began his work in November 1989 after two University of Utah chemists and others claimed to have discovered cold fusion.*

*"However, scientists worldwide had spotty results to duplicate the work of the chemists Stanley Pons and Martin Fleischmann. Even those that did obtain positive results had difficulty repeating the process, and no one has been able to obtain cold fusion on demand.*

*"But Ying's announcement may reopen the controversy over similar claims that have never been fully substantiated.*

*"We are sure we have obtained cold fusion which we can initiate on demand,' Ying announced at a news conference after a demonstration at the Orlando Science Center.*

*"This is subject, of course, to the rigorous review of my peers,' added Ying, who is an adjunct professor at the University of Central Florida and president of Quantum Nucleonics Corp, of Orlando.*

*"He said he and a co-worker, Charles W. Shults III, developed the process over the past three years and have conducted 102 successful experiments.*

*"We are able to get much more heat than we put in, repeatedly,' Ying said after the demonstration observed by U.S. Rep. George E. Brown Jr., D-Calif., chairman of the House Science, Space and Technology Committee.*

*"Brown and U.S. Rep. Jim Bacchus of Orlando, a member of the committee, said they were hopeful that Ying's process could be scientifically proved.*

*"I will probably assign some of our best staff people to this right away,' said Brown, who was surprised by the disclosure while on a visit to Orlando with Bacchus."*

## A CRITICAL REVIEW OF FREE ENERGY

### A CRITICAL REVIEW OF THE AVAILABLE INFORMATION REGARDING CLAIMS OF ZERO-POINT ENERGY, FREE-ENERGY, AND OVER-UNITY EXPERIMENTS AND DEVICES

#### Abstract

A summary review is presented of the experiments, motors, generators, devices, and demonstrations that have been reported in the past few years to produce near-unity or over-unity operation.

The concepts of free-energy, zero-point energy, and over-unity devices are not new, and many examples of such devices have been built within the last 100 years. 26 researchers are reviewed and 11 are selected for immediate interest and support. Whether a new form of potential energy can be demonstrated and successfully utilized within the near future for the ultimate benefit of the human race remains to be seen.

#### Definitions

'Energy' cannot be created nor destroyed - it exists throughout space and within matter.

'Perpetual Motion' does not exist -long lasting motion is easily observable, such as planetary orbits.

'Stupidity' is not hereditary - and it is not a survival trait.

'Zero-Point Energy' (ZPE) is known as an energy that fills the fabric of all space. Technically the ZPE results from an electric flux that flows orthogonally to our perceived dimension or reality. The mass equivalence of this energy has been calculated by physicists to be on the order of 1093 gms/cm<sup>3</sup>. Henry T. Moray, Walter Russell, and

Nikola Tesla described the nature of the ZPE and designed and built equipment to engineer its properties. It may be possible to build devices to cohere this energy. This would result in a non-polluting, unlimited supply of virtually free energy.

'Free Energy' is a term that can have two meanings: either

the additional energy that can be obtained from a device at little or no additional cost, so the additional energy is essentially free; or more output energy that appears to be available than input energy, such as in the case of detonating an atomic bomb.

'Over-unity Devices' are those systems which appear to produce more energy than they use. In analyzing such systems, a box is drawn around the device and energy balances are formulated to measure the amounts of energy coming into and out of that box. Whether or not the device is termed an 'over-unity' device will depend upon the size of the box. When the box is drawn large enough, all systems or devices will have a net energy transfer of zero. On the other hand, when the box is drawn just small enough, the device can be said to be an 'over-unity' device, and an intelligent physicist will know better. From this point of view, examples of existing so-called free-energy devices abound: such as Hoover Dam.

So then is any generator, or any nuclear reactor. More energy certainly comes out of a dam than went into making it (by us, at least). And any dam engineer will tell you that it will produce more energy than it cost to build and that it will last forever (or at least until his kids get out of college).

So it is seen that these generators can be thought of as free-energy devices, while they are really only energy conversion devices, and obviously not perpetual motion machines. People who insist that they actually are, are either very ignorant or very devious. In such cases, examine the person's true motives.

### **Sources of Information and Data**

Ultimately, the sources for all information in these areas come from the inventors, researchers, or investigators themselves. The US and foreign patent offices provide some information into new developments in these areas, yet the actual patents reveal very little useful information and almost no experimental results.

Patent law does not require complete disclosure of all data, and patents are held nationally. An interesting area of big business today is the international transfer of patents at no cost.

Other sources of information and data include papers, reports, books, and conference proceedings. Papers and books that are of special interest are those by : Hans Coler (1946), the Gravity Research Group (GRG1956), Stefan Marinov (1992), Hans Nieper (1984), and Shinichi Seike(1992).

Conferences that have been recently held to collect and summarize information in these areas include the 26th and 27th Intersociety Energy Conversion Engineering Conferences (1991 and 1992) and the more recent International Symposium on New Energy (ISNE) (April 1993).

All of these materials are available from the sources identified in the References section. As a result of a 1993 ISNE working group, the working devices were categorized into four distinct areas:

- (1) Solid-State Space-Energy Generators,

- (2) Rotating Space-Energy Machines,
- (3) Fusion Conversion Devices, and
- (4) Hydrogen Energy.

### **Summary of Interesting Theories, Experiments, and Devices**

"Some things have to be believed to be seen." [1] There are several societies and conferences world-wide that present and sometimes document the results of research in these areas. As this work is not considered as mainstream science within the US, much of the results of these researchers goes by unnoticed.

The 26th IECEC (1991) provided a forum for researchers in these areas to voluntarily come forward and present their ideas, theories, and results to the mainstream scientific community. They were met with interest ranging from mistrust to awe, and from feelings ranging from friendship to outright anger. The ranges of these attitudes will likely depend upon the emotional stability of the listeners.

The 26th IECEC created international interest that stimulated further review papers to be published in the later IECECs. A growing group of organizations is networking on a world-wide basis to support and organize this on-going research. Some of these organizations are listed in the references (AREI, AFS, GRI, IASA, INE, ITS, JPI, SEA, TI, and USP).

"New Energy News" is the new monthly newsletter of Institute for New Energy (INE), a recently formed US technical society, created in April 1993, that is committed to researching these technical areas. Note that the references include complete and accurate address and cost information, so that serious investigators have no excuse to not investigate.

This review includes all of the information that was made available to the 1991 IECEC, the 1992 IECEC, the 1993 International Symposium on New Energy (ISNE), and other contributed personal source information and documents. Our focus here is on actual data and results - not on ideas or mathematical theories. Our emphasis here is on repeatable experimental evidence - or on the documented testimony of multiple reliable witnesses that have been willing to stand-up, testify, and document a description of what they witnessed. Just because you don't see it doesn't mean that it's not real! The list of the researchers, experiments, devices, and results that were addressed in this review are listed in Table 1.

The reference corresponding to each researcher is also listed. Videotapes were made of all ref. speakers at the 1991 IECEC and the 1993 ISNE.

## Possible Misleading Results

"But goodness alone is never enough. A hard, cold wisdom is required for goodness to accomplish good." [2]

We feel that the interpretation of anyone's results can fall into one of four categories:

- (1) Lying for attention;
  - (2) Lying for money(funding, stock options, etc.);
  - (3) Inaccurate measurement or misinterpretation of the data or results;
- and
- (4) Accurate representation of the physical phenomena.

In our reviews, we found absolutely no evidence that any one of the researchers we studied in Table 1 belonged specifically in categories (1) or (2) (although so far as we know three of these researchers have not been able to replicate their initial published results).

Frauds are quickly discovered, if encouraged to reproduce their results and to provide detailed information. So, we were left to carefully analyze the results from each researcher and to carefully draw our own conclusions.

### Table 1. A Listing of Researchers and their Experiments and/or Devices of Current Interest Researcher(s) Experiments, Devices, and Demonstrations References

Adams, Robert  
Adams Pulsed Motor Generator and Replication  
Adams 1993

Baumann, Paul  
Methernitha Swiss  
M-L Converter Device et. al.  
Demonstrations IECEC 1991

Bedini, John  
Bedini Free Energy Generator Plans and Demonstrations IECEC 1991

Binder, Timothy  
Russell's Nuclear-Magnetic Transmutation  
ISNE 1993 Experiments

Brown, Paul  
Nuclear Resonant Generators and Demonstrations  
IECEC 1991

Coler, Hans  
Magnetstromapparat and Stromerzeuger  
Coler 1946 Devices / Demos.

Grotz, Toby  
Russell's Power Multiplication Principle IECEC 1992, Experiments  
ISNE 1993

Hathaway, George  
Unipolar Dynamo of Novel Construction IECEC 1991, Experiments  
ISNE 1993

Hickox, Barbara  
Electric Dynamo Patent  
IECEC 1991

Johnson, Gary  
Electrically Induced Explosions in Water IECEC 1992 Experiments

Kelly, Don  
Electromagnetic Antigravity Drop Tests ISNE 1993, SEA

Lambertson, Wingate  
WIN Process  
IECEC 1991

Marinov, Stefan  
Venetin Coliu Generator Demonstrations ISNE 1993

McKie, Richard  
Power On Demand Module Concept (PODMOD) IECEC 1991

Meyer, Stanley  
Water Fuel Cell Demonstrations  
ISNE 1993

Moray, John  
T. Henry Moray's Radiant Energy Device IECEC 1991

Muller, William & Kevin  
Muller Motor/Generator  
IECEC 1991

Newman, Joseph  
Magnetic Fields Utilization Energy Machine  
Newman 1993

dePalma, Bruce  
N-Machine Experiments  
IECEC 1991

Pappas, Panos  
Energy Creation in Sparks and Discharge Experiments  
IECEC 1991

Reed, Troy and Evelyn

Reed Magnetic Motor Experiments  
IECEC 1991, ISNE 1993

Seike, Shinichi  
Negative Energy and Landau Oscillator Experiments  
Seike 1992

Storms, Edmund  
Established Cold Fusion and Reproducible Results  
IECEC 1993

Sweet, Floyd  
Vacuum Triode Assembly Device Demonstrations  
IECEC 1991

Tewari, Paramahansa  
Space Power Generator Experiments  
ISNE 1993

Valone, Thomas  
Homopolar Generator Experiments  
IECEC 1991, ISNE 1993

While on one hand some researchers may possibly be overstating the capabilities and results of their experiments and devices, on the other hand many so-called 'scientific experts' are very active in discounting ALL of the research results in these areas without investigating the details of any of them.

"The Nobel chemist Irving Langmuir (1881-1957) used to give a cautionary talk on pathological science, and ... told a number of stories of pathological science and listed the features they have in common." (Cromer, Skeptical Inquirer, 1993).

In his eight page article, Cromer states that there are many lessons from this:

- (1) Scientists themselves are often poor judges of the scientific process;
- (2) Scientific research is very difficult. Anything that can go wrong will go wrong;
- (3) Science isn't dependent on the honesty or wisdom of scientists.
- (4) Real discoveries of phenomena contrary to all previous scientific experience are very rare, while fraud, fakery, foolishness, and error resulting from over enthusiasm and delusion are all too common.

Thus, Glashow's closed-minded 'I don't believe a word of it' is going to be correct far more often than not." Cromer also cites Langmuir assaying (Langmuir 1989): "There are cases where there is no dishonesty involved,



but where people are tricked into false results by a lack of understanding about what human beings can do to themselves in the way of being led astray by subjective effects, wishful thinking, or threshold interactions. These are examples of pathological science. These are things that attracted a great deal of attention. ... [But] the critics can't reproduce the effects.

Only the supporters could do that.

In the end, nothing was salvaged. Why should there be? There isn't anything there. There never was." Our sincere response to you is:

If there is no initial interest - then there will be no investigation.

If there is no investigation, there will be no research to replicate. Your interest will spark the urge to replicate. If there IS interest, research, and no replication, then that fact should be published and disseminated with integrity.

If there are witnesses to the results and the results were or are repeatable, then we feel the fault and blame lies with the critic and not with the researcher.

Therefore, given the experiments and devices referenced in this paper: Demand that they be tested with an open mind!

One success out of all of the failures is more than worth the effort!

**Devices of Great Interest**

"Grant shook his head. It's been discussed, in the field. Many people imagined it was coming. But not so soon."

"Story of our species, Malcolm said laughing. Everybody knows it's coming, but not so soon."[3]

**Table 2. A Listing of Promising Devices of Great Interest with Documented Demonstrations**

Researcher(s)	Effects Observed	Yrs	Cat	Doc	MWs	RDs	Res	Eff
Baumann, Paul et. al.	Over-Unity, Rotating, Self-Sustaining	1984+	2	Y	Y	Y	N	N
Binder, Timothy	Chemical Dependency on E-M	1927+	1	Y	Y	Y	Y	N
Coler, Hans	Gravitational Field Generator	1942+	1	Y	Y	Y	N	N
Grotz, Toby	Over-Unity, Rotational Generator	1961+	1	Y	Y	N	Y	N
Kelly, Don	E-M Field Drop Tests & Oscillators	1992+	1	Y	N	Y	Y	N
Marinov, Stefan	Anti-Lenz Effect Motor/Generator	1988+	1	Y	Y	Y	Y	N
Meyer,	Energy from Water,	1980s	4	Y	Y	Y	Y	N

Stanley	H2 Fracturing								
Moray,	Over-Unity,	1930s	1	Y	Y	Y	N	N	
John and	Self-Sustaining Device								
Kevin									
Storms,	Over-Unity Thermal,	1990s	3	Y	Y	Y	Y	N	
Edmund	Cold Fusion								
Sweet,	Over-Unity,	1990s	1	Y	Y	Y	N	N	
Floyd	Steady-Variable Device								
Tewari,	Over-Unity Rotational	1993	2	Y	N	Y	Y	N	
Paramahansa	N-Machine								

Key : Yrs Years the Effects were observed.

- Cat Categories 1 through 4, as defined under 'Sources of Information and Data.'
- Doc Documentation Exists (Yes or No) (Y/N).
- MWs Multiple Witnesses Testimony (Y/N).
- RDs Repeated Demonstrations (Y/N).
- Res Currently Being Researched (Y/N).
- Eff Large Research Effort (Y/N).

The researchers and the works that we feel are worthy of great attention in the near future are those that are listed in Table 2.

It should be noted that some researchers have been omitted from Table 2 only because either their work is of a proprietary or confidential nature, or because we could not obtain the required data or documentation from witnesses.

Such researchers include: Paul Brown, Bruce dePalma, and the Reeds.

All of the researchers listed in Table 1 and not listed in Table 2 have provided and we trust will continue to provide important contributions to and documentation of their work.

In fact, some of this work may turn out to be more important than those currently listed in Table 2. However, at the present moment of time; as this paper is being written, we considered those devices listed in Table 2 to be of the greatest interest to us.

**Summary Information and Data**

Testatika - The Methernitha Swiss ML Converter developed by Paul Baumann and the Methernitha spiritual community in Switzerland has been repeatedly demonstrated to many scientists upon request (26th IECE C, Nieper 1984,SEA). Its three foot counter-rotating disks and specially designed energy storage system are reported to generate a steady output power of

about 3 to 5 kilo-Watts (kW) indefinitely - while sitting on top of a table. A videotape has been produced and its narration has been transcribed.

Russell - Tim Binder and his team have replicated the 1927 experiments of Walter Russell and have created fluorine from pure water vapor using complex E-M field arrangements. This work validates Russell's theories about nuclear structure and the proper arrangement of the Periodic Table of the Elements.

Coler - Hans Coler demonstrated two major devices to many amazed witnesses and officials in Germany during 1925-1945. A 60 kW device was built in 1937, and the war bombings ended further research in 1944. A complete 32 page report declassified by the British Intelligence Objectives Sub-Committee is available. (Coler 1946, Nieper 1984). The theories expressed are very similar to those presented in a comprehensive report (GRG 1956) (the latest one we could find so far) on electrogravitics systems, interactions of E-M with gravity, or counterbary control devices.

Toby Grotz and his team are planning to replicate the energy experiments of Walter Russell. In the fall of 1959, General Chapman, Colonel Fry, Major Sargent, Major Cripe, and others from NORAD in Colorado Springs, attended a meeting at Swannanoa, Virginia (University Of Science And Philosophy) at the invitation of Walter Russell.

At this meeting Russell explained the workings of a device he proposed to build to take advantage of the vacuum state energy, and the two directional movement of energy from gravitation, (generation), to radiation, (degeneration).

During the following year Russell, his wife, Lao, and their assistants built the device. The prototype that was built consisted of two sets of dual and magnetically-sexed coils. On September 10, 1961, Walter and Lao Russell reported to their contacts at NORAD, that the coils had worked and that the President of the United States could announce to the world that a "greater, safer power than atomic energy" could be provided for industry and transportation.

Don Kelly is the editor of the Space Energy Newsletter (SEA) and has been conducting and reporting results of E-M to gravity drop tests. He finds that energized coil assemblies have a 40% lag in drop time over about five feet. Other related research world-wide verifies that spinning masses appear to lose weight at high rotational speeds.

Stefan Marinov is the editor of Deutsche Physik in Germany and has demonstrated many experiments that confound conventional E-M theory. His recent paper describes devices that create anti-Lenz effects, thus increasing the generator's efficiency.

Stanley Meyer has obtained over 28 patents in both the US and other countries that document his water fuel cell and hydrogen fracturing process technology. He began this work in 1980 and has spent over \$1.6 million. Although he has been approached to sell the technology, he says he has no intention to do so and plans to retain control to make sure his invention is brought to the public for the good of mankind. An informative and recommended videotape of his 1993 ISNE presentation is available through the INE.

John and Kevin Moray are pursuing the technology that was repeatedly demonstrated to the press in the 1930s by T. Henry Moray. One device was reported to generate 50 kW for long periods of time by itself. Edmund Storms has reviewed much of the work done internationally in the so-called area of 'cold fusion' and has documented the results and repeated results of the now world-wide research in this area.

Floyd Sweet demonstrated his vacuum triode device to at least two expert electronics technicians that have documented their observations in sworn affidavits. A videotape was also made during a demonstration. From a nine volt battery starter unit, nearly continuous output powers of 500 W to 50 kW have been reported to be observed. Experimentation is still in progress to further refine the device and to improve its operational capabilities.

Paramahansa Tewari has been doing experiments with a N-Machine and has reported over-unity operation from instrument readings. He is currently performing new experiments to feed the output of the device back into the input to obtain a 'free-running' condition.

Many researchers have performed experiments with these devices, also called, homo-polar generators, or unipolar dynamos. They usually consist of a rotating magnetic disk where electrical current is passed from the center of the disk to its edge. Small increases in the motor input power result in large increases of output power, thus encouraging the idea of an over-unity cross-over point.

Regardless of all of the theory and reasons pro and con, it will be exciting to see the results of Tewari's forth coming experiments and videotapes. It appears that all serious research and development activities in the energy conversion technologies will continue to be closely monitored and guarded by the existing oil, transportation, and economics industries.

Serious researchers in these new areas (Meyer, Methernitha, Sweet) are not allowing "the establishment" to buy them out. At the same time, there is strong evidence of aggressive suppression. The German company Becocraft specializing in the development of "new energy devices" was forcibly shut down and its president quickly imprisoned on investment fraud

charges in a court case that had only one plaintiff: the Utility Company of Cologne! (Marinov 1992).

All of the investors of Becocraft fought the case to no avail. Closer to home, the US Patent Office has classified over 3,000 patent devices or applications under the secrecy order, Title 35, U.S. Code (195 2) Sections 181-188.

Where did that technology go? These patents would be a great place to start for a new company involved with defense conversion technologies for environmental use!

## Conclusions

"Woe to you, you blind leaders of a hoard of blind, who say: 'This should be done and that should not be left undone.' You only represent a false teaching and ignore the laws of Creation." [4]

"It has been said that science is man's futile attempt to understand Nature. While it becomes important to learn, understand, and apply science in our everyday lives, it is equally important to continue the pursuit of unraveling the secrets of Nature." (ISNE 1993, from Forward 1).

If ignorance was a good enough reason to not try, the light bulb would have never been invented and the Earth would still be flat. Let us be judged by our work and repeatable results, and not by hasty words. If some of these works turn out to be not valid: So Be It; Let it Be Known; and Let's Move Forward with Integrity!

We are all desperately looking for the next big breakthrough in modern physics to assist us in solving the escalating energy and environment crises!

Do something to promote and encourage the continuation of these researchers and these works! If you don't do it, who will? If not now, when?

## References

26th IECEC, Proceedings of the 26th IECEC, Volume 4, pp 329-492, August 1991: American Nuclear Society, 555 North Kensington Avenue, La Grange Park, IL 60525, \$275.00. 27th IECEC, Proceedings of the 27th IECEC, Volume, pp 4.357-4.295, August 1992: Society of Automotive Engineers, 400 Commonwealth Drive, Warrendale, PA 15096-0001, Order No. P-259, \$350.00. 28th IECEC, Proceedings of the 28th IECEC, August 1993: American Chemical Society, Meetings Department, 1155 Sixteenth Street N.W., Washington D.C. 20036, \$310.00.

Adams, R. "The Adams Pulsed Motor Generator Manual," Jan. 1993: Nexus New Times Magazine, PO Box 30, Mapleton Qld 4560, Australia, \$50.00.

AERI, Advanced Energy Research Institute, 14 Devonshire Mews West, (yes, MEWS not News!!) London W1N 1FP, Great Britain.

AFS, Academy for Future Sciences, PO Box FE, Los Gatos, CA 95031.

Coler, H., "The Invention of Hans Coler, Relating to an Alleged New Source of Power," British Intelligence Objectives Sub-Committee report No. 1043 Item 31, 32 pp, Now Unclassified, Summer 1946. (Available from the authors for \$5.00)

Cromer, A., "Pathological Science: An Update," Skeptical Inquirer, Vol.17, pp 400-407, 1993.

Figgie, H. E. Jr., Bankruptcy 1995: The Coming Collapse of America and How to Stop It,

Little, Brown and Company, US and Canada, 1992.

GRG, Gravity Research Group, "Electrogravitics Systems: An Examination of Electrostatic Motion, Dynamic Counterbary, and Barycentric Control," Feb. 1956: Gravity Research Group report GRG-013/56,

Wright Patterson AFB Technical Library, Catalog No. TL 565 A9, WPAFB, Ohio 45433.GRI, Group Research Institute, PO Box 438, Nelson, New Zealand.

IASA, Institute for Advanced Studies at Austin, 4030 Braker Lane W., Suite 300, Austin, TX 78759.

INE, Institute for New Energy, 1304 South College Avenue, Fort Collins, CO 80524, \$40.00/yr.

ITS, International Tesla Society, PO Box 5636, Colorado Springs, CO 80931.

ISNE, Proceedings of the International Symposium on New Energy, April 16-18, 1993: International Association for New Science (IANS), 1304 South College Avenue, Fort Collins, CO 80524, (303) 482-3731, \$45.00 for both the IANS and INE. IANS supports the INE.

JPI, Japan Psychrotronic Institute, c/o Shiuji Inomata, Electrotechnical Laboratory, 1-1-4 Umezono, Tsukuba-shi, Ibaraki 305, Japan.

Langmuir, I., "Pathological Science," Physics Today, 42: 36-48, October 1989.

Marinov, S., "Regarding Becocraft - Letter to Mr. Richard von Weizsacker, President of the German Federal Republic, 10 October 1992", Deutsche Physik, No. 7, East-West Publishers, Morellenfeldgasse 16, A-8010 Graz, Austria.

Meyer, S. Water Fuel Cell Technical Brief, July 1991: Stanley A. Meyer, 3792 (street missing from file!!) Grove City, OH 43123, \$25.00.

"New Energy News", PO Box 58639, Salt Lake City, UT 84158-8639: monthly newsletter free to INE members.

Newman, J., The Energy Machine of Joseph Newman, July 1993: Joseph Westley Newman, Route 1, Box 52, Lucedale, Miss. 39452, \$60.00.

Nieper, H. A., Revolution in Technology, Medicine and Society, MIT Verlag, Germany, 1984 (In English): Tesla Book Company, PO Box 121873, Chula Vista, CA 91912, \$27.00.

SEA, Space Energy Association, PO Box 11422, Clearwater, FL 34616.

Seike, S., The Principles of Ultra Relativity, 11th Ed., 1992: Space Research Institute, Box 33, Uwajima, Ehime (798), Japan, \$70.00.

Storms, E., "The Status of 'Cold Fusion'," 28th IECEC paper, August 1993.

TI, Tesla Incorporated, 820 Bridger Circle, Craig, CO 81625.

USP, Univ. of Science and Philosophy, Swannanoa Place, Box 520, Waynesboro, VA 22980.

### **Acknowledgments**

The authors gratefully acknowledge these and many other researchers, scientists, and skeptics that have contributed serious open research and documentation to boldly advance science and technology for the benefit of the human race.

### **Footnotes**

1. Poltergeist, Screenplay to the MGM/UA film production and VHS videotape, 1987.

2. Heinlein, Robert A., Stranger in a Strange Land, Berkley Books, 1982.

3. Crichton, Michael, Jurassic Park, Ballantine Books, 1990.

4. Rashid, Isa; Meier, Eduard. The Talmud of Immanuel, 24:29-30, 1990: Wild Flower Press, PO Box 230893, Tigard, Oregon, 97224, \$17.20.5. Complete addresses and total prices are given.

# THE STANDARD OIL TRUST

**BY LEO TANNER**

---

## **Preface**

When I refer to the Standard Oil Trust, I mean a group of businesses that started with the Standard Oil Trust of John D Rockefeller, William Rockefeller, and associates. Through mergers and joint agreements this trust has grown to gigantic proportion. By contributing heavily to collages, political campaigns, governments, and public TV; they control the government, Public Television, and many of (if not all) the institutions of higher learning. Their, almost, complete control of the commercial media has given them, almost, complete control of the government. Vice President Albert Gore, ex-President George Bush, and ex-Vice President Nelson Rockefeller are heirs to the Standard Oil Trust Fortune.

They are extremely secretive because they were almost put out of business by the government and media at the first part of this century. Their focus on controlling the media and government comes out of that experience. They have always been secretive.

This is not a conspiracy theory. It is based in the facts of financial reports and historical documents.

Citi Bank, Chase Manhattan Bank, Pennsylvania Railroad, Union Pacific Railroad, Exxon, Brown Brothers & Harriman, Merrill Lynch, J P Morgan, and Leman Brothers Kuhn & Loeb are original Standard Oil Trust Corporations; and are still controlled by the trust. If a company have a executive that is in an executive for a Rockefeller corporation, old Standard Oil Trust Corporation, or a Rockefeller/Standard Oil Trust organization; it is a good indication that he/she is a Standard Oil Trust Executive and the company is a Standard Oil Trust Company.

## **My American Journey**

All the well known United States Presidential Candidates in 1996 represent the large international corporate business community. This community works together to exploit the worlds resources.

This book is a view of the world as I see it. It tries to not take sides. Of course, I have been shaped by my life experiences. I have done extensive research before writing this book. It is not a Republican, Democratic, Libertarian, Green, John Burch, Communist, LaRouche, Perot, New Alliance,



etc book. After collecting and analyzing the data, I have concluded that America is controlled by the people that control the international corporations and banks.

My first recollection of politics was hearing my uncles discuss politics around the dinner table in a small Southern Utah town. They were conservative Republicans, and my Uncle Don had served in the Utah State Legislature in Salt Lake City. My grandfather had served in the legislature before him. My Uncle Don was going to the University of Utah and would come home every weekend. I do not remember much about the conversations, except I knew I did not want to be a politician.

I do remember one statement that struck me as strange as a child. He used to say with bitterness in his voice: more legislation is passed in the halls, hotels, and bars than on the floor of the legislature. He would give a strange chuckle and walk away. I stayed away from politics for most of my adult life. I did not register to vote or vote for a candidate until 1990. In 1990, I registered as a Republican to re-establish residency in California. In 1992, I changed my party to Democrat. Jerry Brown was the first politician I voted for. I am sure that part of my analyses of the American political process has been shaped by my uncles conversations 40 years ago and my life experiences.

What led me to write this book has been a long process. I was staying in a rooming house in San Jose California when the war in Iraq broke out. I was watching television with one of the residents of the rooming house. He was an older gentleman in his 80ies. As we talked about the coverage of the war, he told me that George Bush was an oil executive. This struck me as strange. All the television coverage I had seen depicted him as a working man. I went to the library and did some research. To my amazement, I found that he was an ex-oil executive; and that his father was an ex-banker and US Senator.

When I was in the US Navy, one of my assignments was the procurement of a submarine weapon system that had the capability of firing Tomahawk Missiles. As I watch the missiles strike their target, I became extremely angry. In my heart, I knew I had been used to further the interests of the international corporations. As I watched the coverage of the war, it became obvious (to me) that the news was being censored. This caused me to research the media. I found that Prescott Bush (George Bushs father) had sat on the board of directors of CBS. Further research showed me that the Bush family fortune was part of the Averel Harriman fortune. He was the heir to the Union Pacific Railroad fortune and a Washington bureaucrat. He had advised every President from Roosevelt to Johnson. As I researched further, I found that the Harriman Fortune was part of the massive international Rockefeller Fortune. I was so outraged at these findings, I vowed to do every thing in my power to remove Bush from office in the next election. I did some research on all of the major Presidential Candidates. Tom Harkin seemed to be the least likely to be

connected to the international oil corporations. After leaving a voice message at his California campaign headquarters (several times) and not receiving a response, I gave up on working for him. Nebraska Senator Bob Kerry or Ex-California Governor Jerry Brown were my next choices. I attended a support rally for Brown in Los Gatos California (a city south of San Jose). At the rally, they ask us to volunteer to work in the New Hampshire Primary. I volunteered for the campaign and went to Manchester New Hampshire. After the New Hampshire Primary, I worked in the Maine, Maryland, and the Florida Primaries.

The Brown Campaign appeared to be a grass roots campaign. It was extremely disorganized and low budget. Most of the campaign workers appeared to be volunteers. As far as I could tell, Brown and the traveling campaign workers stayed in supporters homes. Except for two nights in a Washington DC hotel room and one night in the car, I stayed in Brown supporters homes. After the Florida Primary, I ran out of money and decided to come home to San Jose. Because I had spent all my money on the campaign, I had to stay in homeless shelters for a month after I returned.

I continued to work for Brown in the California Primary Campaign. After a month of staying in shelters, the collage placement office found me an apartment managers job. This gave me a place to live and the opportunity to continue working in politics.

The Brown Campaign in San Jose was just as disorganized as the rest of the campaign. I helped organize a caucus to choose the delegates that would represent Brown in the Democratic Convention in New York City. The Postal Union brought a lot of their members to the caucus and elected their candidates for the number one and two spots. The head organizer of my district was one of these delegates. I then helped organize a rally in my district for Brown. After distributing fliers and advertising in the local news papers, Browns headquarters cancelled his appearance in my district. Because of in fighting and Browns cancellation, the head of our district quit. As it turned out, Browns cancellation was good. He would have had no place to speak if he had come to our district. The head of our district had not reserved the facilities where he was going to speak!

Brown did not cancel in the neighboring district, so those volunteers that remained in our district diverted supporters to the neighboring districts rally. The head of our district did attend the neighboring districts rally and she went to the Democratic Convention in New York City.

Before I went to New Hampshire, I had studied Browns past and found that he had worked for the law firm of Fulbright & Jaworski. Not once, during the campaign, did they bring this fact up. His literature made it look like he had spent the whole time helping Mother Teresa. Research after the campaign

showed me that Jerry Brown was a corporate lawyer for the international conglomerates. Some of them were international oil conglomerates. I, also, learned that his family was active in the oil industry in Indonesia.

Before Jerry Brown was Governor of California, he worked for the law firm of Tuttle and Taylor of Los Angeles (1966 to 1969). After he was Governor of California, he worked for Reavis and McGrath. In 1988, Reavis and McGrath merged with Fulbright and Jaworski. Jerry Brown stayed with the law firm after the merger. Some of Fulbright and Jaworski's clients are Texaco, Mobil, Mitsubishi, etc. Texaco and Mobil are part of the Standard Oil Trust. Mitsubishi is probably also part of the trust. The research I am doing now appears to indicate that the Standard Oil Trust has agreements with Japanese Companies. When I refer to the Standard Oil Trust, I mean a group of businesses that started with the Standard Oil Trust of John D. Rockefeller, William Rockefeller, and associates. Through mergers and joint agreements this trust has grown to gigantic proportion. By contributing heavily to colleges, political campaigns, governments, and public TV, they control the government, Public Television, and many of (if not all) the institutions of higher learning. Their almost complete control of the commercial media has given them almost complete control of the government. They are extremely secretive because they were almost run out of business by the government and media at the first part of this century. Their focus on controlling the media and government comes out of that experience. They have always been secretive.

My research also showed that Pat Brown (Jerry Brown's father), had a family oil business in Indonesia. Pat Brown also owned interest in the oil company owned by the Indonesian Government.

There are several things that bothered me about the Brown Campaign:

1) It seemed to be international in nature. One of his head campaign workers came from England to work on the campaign. A Frenchman traveled with Brown everywhere he went and had been in Brown's administration when he was Governor of California. An Australian was assigned to travel with me.

2) In New Hampshire there was a captain in the NIS that traveled with Brown everywhere he went. This was before Brown qualified for Secret Service protection. I know that Brown's bodyguard was an NIS Agent because I noticed that he had stickers on his vehicle that indicated that. When I was in the Navy, I was temporarily assigned to guard the entrance to a Naval Base. Because of this, I knew what the sticker of a captain in the NIS looked like. I asked him if he was an active NIS Agent, and he said that he was.

I have since studied all of the major presidential candidates for 1992 and 1996. After studying the facts, I believe that all the well-known candidates are in the pockets of the international oil interests. There were over 64 Democrats and over 54 Republicans running for President in the 1992 New Hampshire

Presidential Primary. The news media covered only 6 Democratic Candidates and only 2 Republican Candidates.

After the elections, I spent a whole year attending every San Jose City Council and Redevelopment Agency meeting. In 1993, I tried to get people to run for city council in my district. No one I asked would run or qualified for the ballot; So I qualified for the ballot and ran.

Before the 1992 election, I had been working with homeless people trying to get them housing. To my surprise, I found that the homeless advocacy and provider groups did not support my campaign. Some of them contributed to the incumbents campaign. I researched some of these groups and found that they receive millions of dollars in funding from the city.

Before I became involved in politics, I came to San Jose looking for work and ended up going to a local community college. When I first arrived in San Jose, I noticed that there was a massive homeless problem. I wanted to help solve the problem, so I joined a group that was trying to shame the city into providing homes for the homeless. There were plenty of homes and old hotels that the city owned. They keep them vacant until they can use the property in future redevelopment projects. Many were historical buildings and could not be torn down or moved without extensive government meetings.

What we did was break into these homes and move homeless people into them. Scott Wagers was the leader of the group and was a master at getting the media to cover our demonstrations. The media coverage of the homeless bothered me. I notice that the media depicted the homeless people as all bums and winos that were violent. Not an accurate depiction at all. About half of the homeless are children.

The city was against the homeless occupying the vacant buildings and used severe tactics to stop us from moving the homeless into these buildings. They used police informants to infiltrate and disrupt our group. When we held demonstrations, they used massive police presence (some times hundreds of police officers). They surrounded our demonstrations with officers on horseback. And so on and so forth.

One of the places we held demonstrations was in front of city hall. At about that time, I began to attend city council meetings. At the city council meetings, I noticed that the city council was not responsive to the citizens who addressed the council meetings. It did not matter if it was a homeowner or a homeless person. This caused me to do a detailed study of the connections between the main players at city hall. My analyses has shown me that San Jose is run by a group of local developers and card club owners backed by the international banks and corporations. Some (if not all) are part of the Standard Oil Trust.

While I was traveling with the Brown Campaign, I noticed that every major city had massive redevelopment projects and that they had a massive homeless problem. (Boston, New York, Manchester, Chicago, Orlando, Washington DC, etc.) I researched this and found that redevelopment projects are one of the major causes of homelessness (along with loss of heavy manufacturing jobs, women entering the work force, two income families, illegal immigration, immigration, closing of mental hospitals, disintegration of the family, international trade deals, etc).

After I ran for city council, I backed what I thought was a conservative candidate that had no ties to the internationally financed local power structure. He was a Perot supporter in the last Presidential Election. He had just finished running for city council in a special election on a platform of no growth in San Jose. The previous councilman for that district had resigned before the end of his term. To temporarily fill the vacant seat, the city held a special election. My friend had run in the special election and had lost. The next year the city will hold an election to permanently fill the council seat. I told my friend that I would work for him in the next campaign if he would provide me with housing, food and clothing. He agreed, and I quit my job and began to campaign. To my amazement he was not interested in going door to door and talking to the voters. I tried to get him to support a group of homeowners that were trying to stop open air composting next to their homes. He was only slightly interested. His lack of interest made me curious.

I started to investigate him. He owned a small tree trimming business. I noticed that most of his business clients were developers. More than half of his business came from a contractor who did contraction for the development contractors that donated heavily to city council elections. I now think that all of the candidates in the special election were financially connected to the international redevelopment interests. I may have been the only candidate in the city council race in my district that was not connected to the developers. I did extensive research on my employer and could not find any connection to the international trusts.

My boss has partnerships with professors of California universities. One possibility is they are receiving grant money from the Standard Oil Trusts foundations. My supervisor did not want me to run for city council. When I told her I was running for city council, she hinted that I could not work for CASCO Property Management and run for city council. I am not saying that all the city council candidates did anything wrong or improper. What I am saying is that the influence of the international Standard Oil Trust has become too powerful and controlling. It is, almost, impossible to not work for the international Standard Oil Trust in some capacity. It is impossible to not be affected in some way by their activities.

## Executives and Companies

The following Table includes a partial listing of Standard Oil Trust executives and the companies they represent. It focuses on how they are related to the 1996 Presidential Candidates, the news media, San Jose City local politics, and companies and executives covered in this book.

I hope that this information will be valuable in research you may choose to do about your area. Please, help stop the purging of historical books from the library system in your area. Please, don't vote for a media packaged candidate!! We deserve better.

# means former executives in a corporation

· San Jose local contractor

National Boston	Malklel Burton G #	Volcker Paul A #
Pierce Samuel R Jr	Amerada Hess	
	Spencer William Ira #	American Stores
3M		Preiskel Barbara #
Ridgeway Rozanne	Ameribanc	
Abbott Labs	Price Charles #	Amoco
Bere James Frederick		Fuller H Laurence #
Jacobson Allen F	American Airlines	
	Hills Carla #	AMR
ADM	Fisher Charles	Fisher Charles III
Strauss Robert	Ferre Antonio	Carroll Thomas #
Rockefeller Mrs Nelson		Ferre Antonio
Andreas Dwayne	American Bancorp	Burr Francis #
AEA Investors	Price Charles #	Boren David
Opel John R		Lyon William
	American Bank and Trust	
Aerojet General	Price Charles #	Andrew W Mellon
AIG		Foundation
Hills Carla	American Can	Rhodes Frank #
Akin Gump Strauss	ONeal Paul #	
Hauer & Feld		Anheuser-Busch
Jordon Vernon	American Express	Warner Douglas #
Strauss Robert	Kissinger Henry	
Allen Bradley	Jordan Vernon Eulion Jr	Aon
Wright Lindsey &	Lewis Drew	Vagelos Roy P #
Jennings	Penske Roger S #	
	Robinson James Dixon #	
Allied-Signal		Apollo Computers
Hennessy Edward L Jr	American International	Mc Kinley John Key #
	Group	Vanderslice Thomas A #
Alumax	Hills Carla #	
Brown Harold		ARCO
	American Mortgage	Slaughter John #
AMAX	Price Charles #	Knowles Marie L #
Brown Harold #		Stewart Robert H III#
Amdahl	American Stock Exchange	

Ariel-Capital Management Lafontant-Mankarious Jewel	Bank of the West Mitchall Otis Small Kim *	Bere James Frederick# Bristol-Myers Gelb Richard Lee# Hurlbert James Henley Henry H# Robinson James Dixon III#
Asarco Butcher Willard C #	Bank One Texas Enrico Roger A # Stewart Robert H III #	Bristol-Myers Squib Gerstner Louis V Sigler Andrew Allen Robert E#
Aspen Institute McLaughlin David T #	Bankers Trust Jordan Vernon Eulion Jr	Brown Brothers and Harriman Gerry Elbridge T Roosa Robert V#
AT&T Communications Wright Lindsey & Jennings Hills Carla Schacht Henry Wyman T. H. Lewis D. Allen Robert E #	Bankers Trust New York Jordan Vernon Eulion Jr Maxwell Hamish Bechtel Hills Carla# Shultz George	Buchanan and Co Buchanan Pat Bulova Watch Tisch Preston Robert#
AT&T Technologies Procknow Donald E #	Beckman Instruments Davis Carolyne K#	Burlingron Northern Railroad Chain John T Jr# Vagelos P Roy#
Atlantic Richfield Gray Hanna Gavin John Slaughter John Cook Lodwick M #	Beecham Group Bauman Robert Patten# Bell Atlantic Ridgeway Rozanne Carlucci Frank	Campbell Soup Beck Robert A#
Automatic Data Processing Tisch Larry #	Bell Atlantic New Jersey Hanson Jon F#	Capitol Cities Casey William#
AVCO Bauman Robert Patten # Avery Dennison Slaughter John	Berliner Cohen Biagini Theodore Bethlehem Steel Trautlein Donald#	Capitol Cities/ABC Murphy Thomas S Bauman Robert Patten Cary Frank Taylor# Spencer William Ira#
Avon Gault Stanley #	Beverly Enterprises Banks David R#	Carnegie Inst Williams Louis Stanton#
Axelson Mfg Bere James Frederick #	Bird-Johnson Trost Carlisle A#	Carnegie-Mellon U Williams Louis Stanton#
Baker Fentress & Co Malklel Burton G #	Boatmens Bancshares Cornelious William E #	Carnegie Corporation Tisch Larry#
Baker Worthington Crossley etc Alexander Lemar	Boeing Ridgeway Rozanne Beck Robert A	Carnegie Foundation
Bank of Boston Corp Vanderslice Thomas A #	Borg & Beck	

Rhodes Frank#	Gray William H III#	Cleaning Machine
	Ward Ralph E	Bere James Frederick#
CBS		
Bush Prescott#	Chemical Bank	Cluett Peabody & Co
Paley William#	Henley Henry H#	Henley Henry H Jr#
Tish Larry	Sigler Andrew C#	
Sauter Van Gorden#	Goodes Melvin#	
Zelman Sam#	Mercer Robert E#	
Kissinger Henry		CNA
Brown Harold	Chesebrough-Ponds	Ridgeway Rozanne
Houghton James#	Ward Ralph E#	Tisch Larry
Schacht Henry#		Tisch Preston Robert
Wyman Thomas H	Chevron	
	Hills Carla	CNN
Celgene	Baker Worthington	Turner Ted
Butcher Willard C#	Crossley etc	Zelman Sam
		Buchanan Pat
Centerre Bancorp	Chicago Tribune-New	
Mahoney Richard John#	York News	Coco Cola
	Buchanan Pat#	Robinson James Dixon
Champion International		III#
Sigler Andrew#	Chiquita Brands	
	International	Colonial Group Mut.
Chase Bank	Linder Carl H	Funds
Kissinger Henry#		Shinn George L#
	Chrysler	
Chase Manhattan Bank	Allen Robert E#	Colonial Williamsburg
Higgins William W#	Zuckerman Frederick W#	Wilburn Robert C
Butcher Willard C		Rockefeller Winthrop#
Kearns David	Citation	
Cooney Joan Ganz	Di Napoli Phil	Comerica Bank
Pratt Edmund T	Biagini Theodore	Di Napoli J Phil
Wilburn Robert C#	Imwall Don	Fisher Max M
Schacht Henry	Mariani Louis J	Lewis John D
Chase Manhattan Corp	Citibank	Comerica California
Cooney Joan Ganz	Braddock Richard S#	Di Napoli J Philip
Schacht Henry B	Evans James Hurlbert#	Bloom Maxwell
Kearns David	Palmer Edward Lewis#	Gibson Drew
Pratt Edmund T	Spencer William Ira#	Lewis John D
Burns M Anthony#	Calloway D Wayne	Wolff Lewis N
Ferguson James L#	Ridgeway Rozanna L	
Finkelstein Edward S#	William Wilson &	Computer Consoles
	Associates*	Vanderslice Thomas A#
(Chase Manhattan Corp.	Reed John S#	
continued)		
Flowerree Robert E#	CitiCorp	Conner Peripherals
Fuller H Laurence#	Evans James H#	Penske Roger S#
Kauffman Howard C#	Ridgeway Rozanne	
McLaughlin David T#	Calloway D Wayne	Continental Bank
Taubman A Alfred#	Reed John S#	Lafontant-Mankarious
Trautlein Donald H#	Smith Roger B#	Jewel#
Whitmore R Kay#		Richman John M#



Continental Ill Nat Bank & Tr	Parsons Richard D#	Lafontant-Mankarious Jewel#
Bere James Federick#	Discount Corp Michelson Gertrude#	Savage Frank# Burr Francis H#
Continental Ill. Corp Bere James Frederick#	DNA Plant Tech Cary Frank#	Ernst & Young Davis Carolyne K#
Corning Jordan Vernon Elion Jr Houghton James R Hennessy John M Burr Francis H#	Donnelley & Sons Company Richman John M#	Esso International Raymond Lee R#
Corning Glass Works Hills Carla Kennear James W III#	Dow Corning Houghton James#	Exxon Colloway D Wayne Kauffmann Howard C# Raymond Lee R#
Crocker National Bank Smith William French#	Dow Jones Jordan Vernon Elion Jr	Fairmont Hotel Swigs Di Napoli J Phil Wolff Lewis Kimbal Small *
CS First Boston Carroll Thomas# Shinn George L Hennessy John Olayan Suliman S	Dravo Hamberger Marlin Edwards Jack Wilburn Robert C Jackson Edward# Williams Louis Stanton#	Federal Home Loan Bank Williams Louis Stanton#
Cubb Michelson Gertrude#	Dresser Industries Murphy John J#	Federal National Mortgage Ass Parsons Richard D#
Cummins Engine Gray Hanna Brown Harold Schacht Henry B Dayton Hudson Enrico Roger A#	Drexel Burnham Lambert Milken Michael Aiken Gump Strauss Hauer Feld	Firemans Fund Robinson James Dixon III#
Dechert Price Rhoads Specter Arlen Birnbaum Robert	du Pont Glore Forgen Perot Ross#	Fisher Controls Mahoney Richard John#
Del Monte Palmer Edward L#	Dun & Bradstreet Myer John Robert#	Fisher Science Smith William French#
Delux Jacobson Allen F#	Earle N Jorgensen and Co Jorgensen Earle N# Price Charles# Smith William French#	FMC Boeschenstein William W# Foodmaker Silberman Richard# Peterson Richard#
Detroit Diesel Corp Penske Roger S#	Eastman Kodak Braddock Richard S# Whitmore Kay R#	Foote Cone & Belding Lafontant-Mankarious Jewel#
Diamond Shamrock Irani Ray R#	EDS Perot Ross# Equitable Life Assurance So.	Ford Motor Wright Lindsey & Jennings
Dime Savings Bank		

Baker Worthington	General Housewares	Hanson Jon F#
Crossley etc	Murphy Thomas S#	
Ford William C		Hanes
Ford William C Jr	General Moters	Lafontant-Mankarious
Lewis Drew	Investmet Manag	Jewel#
	Dee Walter T#	
Fowler Rountree Fowler		Harsco
Robert	General Public Utilities	Mudge Rose Guthrie
Alexander Lamar#	Trost Carlise A#	Alexander
		Smith DeWitt C Jr
Fox	Georgia Pacific	Nixon Richard#
Murdoch Rupert	Flowerree Robert E	Wilburn C Robert
Sauter Van Gordon		
	GM	Harte-Hanks
Freeport-McMoran	Evans H James#	Communications
Kissinger Henry	Pratt Edmund T	Lafontant-Mankarious
Woods Ward Jr	Wyman Thomas H	Jewel#
	ONeal Paul	
Fuji Xerox	Perot Ross#	Henley Group
Kearns David	Fisher Charles III	Hills Carla#
	Evans James Hurlbert#	
Fuji-Wolfensohn	Smale John G	Hilton Hotel
Volcker Paul A#	Smith Roger B#	Hilton Barron
	Potter David S#	Di Napoli J Phil*
GD Searle & Co	Blnns W Gordon Jr#	Wolff Lewis*
Mahoney Richard John#		Hilton Eric
	Goldman Sachs	
GE	Ballard Claude M Jr#	Holiday Inn
Pierce Samuel#		Di Napoli Phil*
Gault Stanley#	Goodbody & Co	Wolff Lewis*
Jones David C	Shinn George L#	Hollinger
Smith William French#		Kissinger Henry
Calloway D Wayne	Goodyear Tire & Rubber	
Mercer Robert	Mercer Robert E#	Hollnee
Henley Henry H Jr	Michelson Gertrude#	Walker Gordon A#
Michelson Gertrude	Gault Stanley C#	
Geraldine	Barrett Tom H#	Holnam
Sigler Andrew Clark		Jackson Edward
Warner Douglas	GTE	Dewitt Frank J
Alexander III	Johnson James L#	
Rhodes Frank	Vanderslice Thomas A#	Home Life
Preiskel Barbara		Henley Henry H Jr#
Stonecipher Harry C#	Gulfstream Aerospace	
Vanderslice Thomas A#	Penske Roger S#	Howard University
		Parsons Richard D#
Gencorp	GUP Nuclear	
McGarry Diane#	Trost Carlisle A#	Hughes Tool
Lafontant-Mankarious		Pickens Thomas Boone
Jewel#	H F Ahmanson and Co	Jr#
	Smith William French#	Bere James#
General Foods		
Ferguson James L#	Hampshire Management	Hyundai
	Company	Baker Worthington

Crossley etc	Fanigan Jack#	Clifford Clark#
IBM	Bren Donald	Koll Co
Brown Harold	Taubman Alfred#	Speno Steve#
Slaughter John	Ford Henry II#	Gibson Drew#
Vine Street Properties*	Petrie Milton#	Koll Donald
Kuehlen Jack D#	Fisher Max#	
Perot Ross#	Allen Herbert Sr#	Lafarge
Gerstner Louis V#	Smith Joan Irvine#	Clinton Hillary#
Hills Carla#	Clark Athalie#	
Murphy Thomas S	Island Creek Coal	Land & Exploration
Gomory Ralph#	Gore Albert Sr	Trost Carlisle A#
Katzenbach Debelleville#	Irani Ray R#	
Burke James S		Lehman Brothers
Beitzel George B #	J C Penney	Hichcock William
Akers John F#	Jordan Vernon Eulion Jr	Mellon#
Opel John R #		
Zuckerman Fredreick W	J P Morgan	Lehman Brothers Holding
	Yearley Douglas	Penske Roger S#
IDS Mut. Fund Group	Gray Hanna	
Laird Melvin#	Cary Frank#	Leisure Lodges
	Warner Douglas	Banks David Russell#
Ill. Bell Telephone	Houghton James	
Bere James Frederick#	Simmons Richard	Lincoln Savings and Loan
	Raymond Lee R	Keating#
Ingersoll-Rand	Ketelson James L#	
Procknow Donald E#	Smale John E	Lockheed
		Yearley Douglas C#
Inland Steel	J Rothschild/Wolfensohn	Trost Carlisle A#
Vagelos P Roy#	Volcker Paul A#	Potter David S#
		Savage Frank#
International Herald	Jack in the Box	Trost Carlisle A H#
Tribune	Peterson Richard#	Cook Lodwick M#
Simmons Richard#	Silberman Richard#	
		Lockheed Martin
International Paper	Jeffrey Company	Alexander Lamar#
Pratt Edmund T Jr	Malklel Burton G#	Baker Worthington
Butcher Willard C		Crossley etc
Pierce Samuel	Jewel Cosmetics	Murray Allen E
Gault Stanley	Lafontant-Mankarious	Laird Melvin
Smith Rodger B	Jewel	Hennessy Edward L Jr
ONeal Paul#		
	Johnson & Johnson	Loews
IPB	Cooney Joan Ganz	Brademas John
Gramm Windy Lee	Murphy Thomas S	Tisch Larry
Peterson Robert L	Smith Roger B	Tisch Preston Robert
Tinstman Dale C	Kerr McGee	
Chalsty John S	Murphy John J#	Lorillard
Courtelis Alec P		Tisch Preston Robert#
Smith Joann Doke	Tenneco	
Irani Ray R	Ketelson James L#	Lotus Development
		Gray William H III#
Irvine Co	Knight Ridder	

Manufactures Hanover MC Kinley John Key#	Vagelos P Roy# Mc Kinley John Key# Cary Frank#	Yearley Douglas C# Robinson James Dixon III#
Martin Aircraft Stonecipher Harry C#	Merrill Lynch Regan Donald# Shinn George L#	Morgan Stanley Fogg Joe
Martin Marietta Alexander Lamar# Laird Melvin# Murray Allen E# MC Kinley John Key# King Gwendolyn S# Vessey John W Jr#	Schreye William# Baker Worthington Crossley etc Crowe William# Small Kim *	Morgan Stanley Group Gilbert S Parker#  Mudge Rose Guthrie etc Nixon Richard# Hills Carla
Mattel Brown Harold Maxwell House Bauman Robert Patten#	Mesa Petroleum Pickens Thomas Boone Jr.#  Met Life Evans James Hurlbert# Laird Melvin	Mudge Stern Baldwin Todd Nixon Richard#  Municipal Bond Investors Ass Gray William H III# Volcker Paul A#
May Department Stores Farrell David C# Bloostein Allan#	Cooney Joan Ganz Ferre Antonio Houghton James R Murray Allen E Mahoney Richard John#	Mutual Broadcasting Systems Buchanan Pat
Mayfair Packing Di Napoli Phil Di Napoli Richard L Melehan Joseph P Melehan James S	Microelectronics and Computer Inman Bobby Ray#	Mutual Fund Group Laird Melvin
Mazda Motor Wright Lindsey & Jennings	Minnesota Mining & Manufacturing Jacobson Allen F#	Mutual Life Insurance Preiskel Barbara#
McDonnell Douglas Stonecipher Harry C Lanese Herbert J McDonnell John Finney Biggs John Herron Byron Beverly Butcher Cornelius William Edward Vagelos Pindaros Roy McDonnell James S III	Mission Viejo Bren Donald#  MIT Reed John S# Mobil Murray Allen E# Lafontant-Mankarious Jewel# Jacobson Allen F#	Mutual of New York Harriman E R # Nixon Richard # Mudge Rose Guthrie Aledxander Barret Tom H# Johnson James L# Ballard Claude M Jr# Meyer John Robert#
McKesson & Robbins Henley Henry H Jr#	Monex International Carabini A Louis	NationsBank Murphy John J#
Mellon Bank Williams Louis Stanton#	Monsanto Mahoney Richard John#	NBC Sarnoff David# Smith William French# Kim Small *
Merck & Co Thomas Franklin A# Davis Carolyne K#	Morgan Guarantee Simmons Richard#	Buchanan Pat# Brademas John Calloway D W

Henley Henry H Jr Jones David C	Stegemeler Richard J#	Smith William French#
Mercer Robert E Michelson Gertrude Rhodes Frank	Northwest Industries Bere James Frederick#	Pacific Telesis Smith William French#
Nestle Volcker Paul A#	Northwestern Airlines Laird Melvin Blum Richard C	Panty Pride Lafontant-Mankarious Jewel
New York International Group Smith William French#	Northwestern University Richman John M# Wolf Stephen M# Vargos P Roy#	PBS Rockefeller Sharon Percy Di Napoli Richard Swig Charlotte Sauter Van Gorden Buchanan Pat Cooney Joan Ganz
New York Stock Exchange Brademas John# Pierce Samuel R Jr# Cary Frank# Shinn George L#	Occidental Petroleum Hammer Armand# Gore Albert Sr. Hammer Michael A Irani Ray R# Krim Arthur B# Syriani Azlz D# Kluge John W#	Penske Corp Penske Roger S#  Penske Truck Leasing Corp Penske Roger S#
New York Times Buchanan Pat# Gelb Richard Lee Gerstner Louis# Price Charles# Shinn George L Vance Cyrus R Akers John F#	Olayan Group Syriani Aziz D#  Olin Irani R Ray# Higgins William W Kuehler D Jack Reed William Henley Henry H Jr# Frederick Robert R#	Pepsico Rockefeller Sharon Perch Cary Frank# Smith Roger B Calloway D Wayne Vagelos Pindaros Roy Akers John F Thomas Franklin H Enrico Roger A Murphy John J Stewart Robert H
Newmont Mining Parker Gordon R#	Orion Pictures Krim Arthur B#	Perot Systems Perot H Ross Jr Perot H Ross Sr Meyerson Morton H
Newport News Shipbuilding & dr Lanese Herbert J#	Owens-Corning Fiberglas Boeschstein William W#	Pfizer Pratt Edmund T Jr# Horner Constance J#
Nissan Motor Wright Lindsey & Jennings	Oxy Oil & Gas Irani Ray R#	Pharmaceutical Marketing Serve Davis Carolyne K#
Northern States Power Company Jacobson Allen F#	Pacific Bell Smith William French#	Phelps Dodge Yearley Douglas Shinn George L Palmer Edward Lewis
Northrop Grumman Edwards Jack Hand Arendall Bedsole etc Slaughter John Jordan Barbara Jackson Edward# Chain John T Jr# Peters Aulana L#	Pacific Lighting Smith William French#  Pacific Mutial	

Knowles Marie L	Burke James#	Reed John S#
Krebs Robert D	Volcker Paul A	
Parker Gordon R	Vagelos Pindaros Roy	Rand Mc Nally
	Enrico Roger A	Myer John Robert#
Philadelphia Electric	Thomas Franklin A	
King Gwendolyn S#	Beck Robert A	Rand Xerox
	Boeschstein William W	Kearns David
Philip Morris	Davis Carolyne K	
Brown Harold	Gray William H III	Raytheon
Wolf Stephen M	Hanson Jon F	Burr H Francis
Murdoch Rupert	Horner Constance J	Rudman Warren
Parsons Richard D	Jacobson Allen F	Eliot Theodore#
Penske Roger S	Malklel Burton G	Sisco John
Reed John S	Opel John R	
Richman John M	Procknow Donald E	RCA
Wolf Stephen M	Vagelos P Roy	Sarnoff David#
Miles Michael A	Volcker Paul A	Harbord James G#
		Brademas John#
Phillips Petroleum	Pullman	Smith William French#
Pickens Boone #	Smith William French#	
Laird Melvin		Readers Digest
Edwards James B	Quaker Oats	Association
Laise Carol	Michelson Gertrude#	Laird Melvin
Beitzel George B #		
	R H Macy	Reed Elliot Creech and
Phillsbury Madison &	Kissinger Henry#	Ruth
Sutro	Michelson Gertrude#	Reed Chuck
Biagini Theodore	Finkelstein Edward S#	Pandori David#
Plaza Bank	R J R Nabisco	Regeneron
Di Napoli Phil#	Ridgeway Rozanne	Pharmaciuticals
Biagini Theodore#	Jordan Vernon Eulion Jr#	Vagelos P Roy#
Imwall Don#	Chain John T Jr	
	Chambers Julius L	Revlon
Portlatch	Clendenin John L	Lafontant-Mankarious
Jacobson Allen F#	Zuckerman Frederick W#	Jewel#
PPG	Ralston Purina	Revlon Group
Gault Stanley C#	Silberman Richard#	Lafontant-Mankarious
Williams Louis Stanton#	Peterson Richard#	Jewel#
	Banks David R	Kissinger Henry#
Price Candy	McDonneld John F	Jordan Vernon Eulion Jr#
Price Charles#	Biggs John Herron	
	Burtis Theodore A	Rockefeller Brothers
Price Waterhouse	Danforth William H	Fund
Cornelius William E#	Farrell David C	Evans James Hulbert#
	Ortega Katherine D	Parsons Richard D#
Procter & Gamble		Kissinger Henry#
Pepper John Ennis Jr		
Smale John#	Rand	Rockefeller Family Office
	Pierce Samuel R Jr	Tru.
Prudential Insurance	ONeal Paul	Shinn George L#
Pierce Samuel#	Michelson Gertrude#	

Rockefeller Fund Brademas John	Seamens Bank Gerry Elbridge T Jr	Taubman Centers Taubman Alfred Taubman Robert S
Rockwell International Gray William H III	Silicon Graphics Jacobson Allen F	Ballard Claude M Bluns W Gordon J Bloonstein Allan J
Rose Law Firm Clinton Hillary# Hubbel L Webster# Foster Vincent# Kennedy William III#	South Co Jackson Edward	Dec Walter T Gilbert S Parker
Royal Insurance Gerry Elbridge T Jr	Southern California First Nat. Silberman Richard# Peterson Richard#	Taubman Investments Taubman William S Taubman Robert S Tubman Alfred
Royal-Globe Ins Palmer Edward L#	Southern New England Telecomm Malklel Burton G#	TCBY Clinton Hillary# Texaco Brademas John Price Charles Murphy Thomas S Cary Frank T# Berk Robert A Butcher William C Crowe William J Jr Kinnear James Wesley III# Mc Kinley John Key# Roosa V Robert# Vanderslice Thomas A# Williams Louis S#
Rubbermade Gault Stanley# Williams Louis Stanton#	Spencer Foundation# Reed John S	
Ryder System Jordan Vernon Eulion Jr Burns M Anthony#	Stanley Works Michelson Gertrude# Stevens Inc Banks David R	
Sainte Clare Baccardo James Di Napoli Phil	Sun Company Burtis Theodore A#	
San Diego National Bank Galinson Murray	Sun Garden Di Napoli Phil DI Napoli R L Mulcahy T E	Texas Commerce Bancshares Pickens Thomas Boone Jr#
San Jose Water DiNapoli Phil Gibson Drew Toeniskoetter Charles	Sundstrand Stonecipher Harry C#	Texas Commerce Bank Amarillo Pickens Thomas Boone Jr#
Santa Fe Pacific Krebs Robert D	Suzuki Baker Worthington Crossley etc	Textron Bauman Robert Patten# Preiskel Barbara#
Sara Lee Ridgeway Rozanne Jordan Vernon Eulion Jr Jacobson Allen F#	Synergen Brown Harold#	
Scholastic Brademas John Mc Donald John G	Taubman Fisher Max# Taubman A Alfred Bloostein Allan J Dec Walter T Gilbert S Parker Taubman Robert S	The News Corporation Murdoch Rupert Maxwell Hamish
Science Applications Davis Carolyne K#		Time Bere James (84) Kearns David

Time Warner	Rose Law Firm	Vanguard Group
Parsons Richard D	Union Pacific Corp	Malklel Burton G#
Carla Hills	Garry Elbridge T Jr	
Miles Michael A#	Henry Kissinger#	W A Harriman
Kearns David T	Palmer Edward Lewis#	Harriman Averell#
	Evans James Hurlbert#	Bush Prescott#
Toyota	Bauman Robert Patten	Walker George H#
Baker Worthington	Simmons Richard#	
Crossley	Gray William H III	Wachtel Lipton Rosen & Katz
		Richman John M#
Tribune	(Union Pacific	
Vagelos P Roy#	Corp.continued)	Wal Mart Stores
	Lewis Drew#	Clinton Hillary#
Trust Co of the West	Mahoney Richard John#	Banks David R
Hills Carla	Meyer John Robert#	
Kissinger Henry	Robinson James Dixon	Warner-Lambert
Spencer William Ira#	III#	Gray William H III#
Turner Broadcasting		
Turner Edward	Union Pacific Railroad	
Levine Gerald	Lewis Drew	Washington Post
		Simmons Richard
Turner Co	United Airlines	Gomory Edward
Pierce Samuel R Jr	Hills Carla	Katzenbach Debelleville
Walker Gordon A	Swigs*	Preiskel Barbara
Zuckerman Frederick W	Armstrong Neil A	Burke James
	Wolf Stephen M	Washington University
TWA		Danforth William H
Lafontant_Mankarious	United Brands	
Jewel#	Fisher Max#	Weitraub Entertainment
U S Trans World	Taubman Alfred#	Smith Henry French#
LaFontant-Mankarious	Lindner S C	
Jewel	Lindner C H	Westinghouse Electric
	Linder K E	Gray William H III
U S West		
Jacobson Allen F#	University of Chicago	Westmark Systems
	Gray Hanna	Inman Bobby Ray#
UAL		
Wolf M Stephen	Unocal	White Weld & Co
Volcker Paul A	Stegemeler Richard J#	Robinson James Dixon
		III#
Union Carbide	US Industries	
Ridgeway Rozanne	Pierce Samuel R Jr#	Wickes Lumber
Jordan Vernon Eulion Jr	Walker Gordon A#	Hanson Jon F#
Union Electric Co St	USX	William Wilson and
Louis	Yearley Douglas	Associates
Cornelius William E	Jones David C#	Wilson William
	Armstrong Neil	
Union National Bank	Richman John M#	Worthen Banking
Arkansas		Wright Lindsey &
Rockefeller Winthrop	Valmont Industries	Jennings
Paul#	Jacobson Allen F#	Rose Law Firm



Rockefeller Winthrop Paul	Jordan Vernon E	Silberman Richard
Wright, Lindsey & Jennings	Inman Bobby Ray	Manatt Charles
Clinton Bill#	Peper John E	Galinson Murray
Xerox	Nicholas Norman J	Dominelli J David
McGarry Diane#	Cooney Joan Ganz	Zurich Insurance
	Beck Robert Alfred	Akers John F#
	Yuba Natural Resources	

### **Deception in High Places**

This Book is about how the international corporations are controlling Americans 1996 election process. All the well known United States Presidential Candidates represent the large international corporate business community: Wilson, Dole, Specter, Buchanan, Gramm, Clinton, Perot, Alexander, Gingrich, Powell, etc.

The major news media outlets are international corporations; they are controlled by the international corporations. Because of this, the major news media cover only the candidates that will further international business interests (international corporate executives, career politicians beholding to the international corporations, career military officers beholding to the international corporations). Since the major news media is how most citizens get the information they need to vote intelligently, most citizens know only about the candidates the major media chose to cover. This means that if the well known candidates are elected, they will not solve the major problems that America faces: immigration, falling standard of living, homelessness, unemployment, national debt, crime, drugs, foreign ownership of US companies, subsidies to foreign countries, over population, over development, inadequate transportation, high cost of living, former politicians that represent foreign governments, monopolies, campaign reform, honesty in government, moral TV programming, political assassination, mass murder of US Citizens by the US Government, mass murder of non-US Citizens by the US Government, etc.

Here is an example. My research has shown that Clinton, Wilson, Gramm, and Dole are career politicians that have received campaign backing from international agri-business conglomerates. Because of this, they will not solve the immigration problem, falling standard of living, homelessness, unemployment, crime, drugs, foreign ownership of US companies, subsidies to foreign countries, overpopulation, over development, former politicians that represent foreign governments. The solutions (to be continued in book)

## **Local Government**

The international corporations are taking over the ownership of the small businesses and homes of the original residences of San Jose by using the local, state and federal governments. They are using their banks and corporations to finance this take over.

San Jose Politics is like the politics in most major American Cities. San Jose's Politics is controlled by the international corporations through local people. To get around the campaign laws, these local people have a network of business partners and associates that donate millions to local elections. These local people are today involved in real estate speculation for the benefit of the international corporations. They are involved in two plans of attack:

1) Their local people pick a rundown part of the city and displace the local residence and merchants. Using city subsidies, their local people then redevelop this area by building high rise office towers, shopping centers, sports arenas, night clubs, convention facilities, luxury condominiums.

2) In the undeveloped areas, they build shopping centers, housing, and apartments using city subsidies. To get the growth necessary to sell these developments, the international corporations have their local and federal people lobby for more immigration. A list of some of the top local people are as follows: Phil Di Napoli, Richard Cristina, Berry Swenson, Otis Mitchall, Yosh Uchida, Drew Gibson, Steve Speno, Mike Fox.

All/some of the international corporations, that control San Jose, are part of the Standard Oil Trust. Some of the international corporations, that control San Jose, are as follows: Comerica Bank, Union Bank, Bank of America, Bank of the West, The Koll Co., Hilton Hotels, IBM, Sumitomo Bank, Industrial Bank of Japan. The former chairman of United Brands (former United Fruit) sits on Comerica's board of directors. United Fruit aka, United Brands aka, Chiquita Brands International is controlled by the Rockefeller Brothers, and has been instrumental in overthrowing governments

## **Bill Clinton**

Bill and Hillary Clinton are in the pockets of the modern Standard Oil Trust and work to advance their corporate interests. They both worked for law firms that represent international corporations and Standard Oil Trust Corporations.

Hillary Clinton worked for the Rose Law Firm. Some of the international clients they represent are General Electric, General Motors, Georgia Pacific Corporation, Tyson Foods, USX Corporation, Wal-Mart Stores, TCBY, etc. Hillary sat on the board of directors of the international corporations Wal-Mart and TCBY.

The Rose Law Firm is one of Winthrop Rockefeller's law firms. While Hillary Clinton worked for the Rose Law Firm, Union National Bank of Arkansas was one of their clients. Winthrop Paul Rockefeller (Winthrop Rockefeller's son) sat on Union National's board of directors until 1992. After 1992, Union National Bank of Arkansas merged with Worthen Bank Corporation. Since 1992, Winthrop Paul Rockefeller has sat on Worthen Bank Corporation's board of directors.

Starting in 1981 through 1982, Bill Clinton worked for Winthrop Rockefeller's law firm (Wright, Lindsey, & Jennings). They represent the Worthen Bank Corporation. Worthen Bank loaned Clinton money for his 1992 presidential campaign. Wright, Lindsey, & Jennings represent international corporations. Some of their clients are: Allen-Bradley Inc, AT&T Communications, Ford Motor Company, General Electric, Mazda Motor Corporation, Nissan Motor Corporation, Worthen Banking Corporation, etc.

The Rose Law firm was very important in the first days of Clinton's Administration. Lawyers from The Rose Law Firm were appointed to the Clinton's first administration. Webster L. Hubbel (convicted in the White Water Scandal) was appointed #3 man at the Justice Department. Vincent Foster (found dead in his car with a bullet through his head) was appointed Deputy White House Counsel. William Kennedy III was appointed Associate White House Counsel.

As Governor of Arkansas, Clinton was instrumental in carrying out the agenda of the Standard Oil Trust. Winthrop, Nelson, Laurance, David, and John D III Rockefeller are the grandsons of John D Rockefeller. They inherited a vast international corporate empire from their grandfather. Their empire is part of the modern Standard Oil Trust. One of Winthrop Rockefeller's assignments was to develop the trust's interests in Arkansas. He was active in politics and was the Governor of Arkansas in 1967 through 1970. While governor of Arkansas, Clinton was instrumental in moving the high-paying industry jobs from the Northern United States to low-wage Arkansas. He raised the state gas tax to build the heavier roads needed to carry raw materials to the new manufacturing facilities and finished goods from the facilities. So the residents of Arkansas would have the level of education necessary to do the new jobs, he raised taxes to pay for the new education facilities.

The close relationship of the Clintons to the Standard Oil Trust is shown by several of their actions:

- 1) Their appointment of Rose Law Firm Attorneys to their administration.
- 2) Hillary Clinton campaigned in the 1967 Draft Nelson Rockefeller For President Campaign.
- 3) Vernon Jordan's assignment to the Clinton White House Transition Team. Vernon Jordan is a partner in Akin Gump Strauss Hauer & Feld in

Washington DC. This is a law firm that represents the Rockefeller Corporations. Robert Strauss is one of the law firms partners and sits on Archer-Daniels Midlands Board of Directors (a Rockefeller agri-business conglomerate). Former Vice President Nelson Rockefellers wife sits on ADMs board of directors. ADMs donations to the Democratic Party helped Clinton win the 1992 Presidential Election.

4) Clintons appointment of Robert Strauss as Ambassador to Russia.

5) John D (Jay) Rockefeller IV (the son of John D Rockefeller III) is a good friend of the Clintons. He was chairman of the Democratic Party (before Ron Brown) and was instrumental in excluding candidates from the 1992 Democratic Primary Debates. He was an ardent supporter of the Clinton Health Care Package. The package would have excluded small insurers from the health care insurance market. It would have given an extreme advantage to the Standard Oil Trusts Companies (like Met Life).

6) The choice of Albert Gore for Vice President. Albert Gore is an heir to the massive international conglomerate Occidental Petroleum Fortune. Occidental was founded by international businessman Armand Hammer. Albert Gore Sr. was a close friend of Hammer and sits on Occidentals board of directors. Armand A Hammer is dead; however Michael A Hammer (Armand Hammers son) sits on Occidentals Board of Directors.

Before the breakup of the Soviet Union, Occidental Petroleum had manufacturing plants in the USSR. They were, also, active in trading grain with the USSR. Today, Occidental is active in developing the oil resources of the former USSR. Some of Occidentals businesses are oil and gas, agri-business, fertilizer, chemical plants, meat processing, etc. Occidental Petroleum is a Standard Oil Trust Corporation. Ray R Irani is the Chairman of Occidental. He worked for Olin Corp from 1973 through 1983: he was on the board of directors from 1980 through 1983.

Olin is a Standard Oil Trust company. William W Higgins and Jack D Kuehler sit on Olins board of directors, Higgins is a former Senior Vice president of Chase Manhattan Bank. Jack D Kuehler is a former Vice Chairman of IBM. (Vice President Gores father and Phil Gramms wife are executives for Occidental Petroleum).

Large international corporations have been instrumental in financing and furthering Bill Clintons career. Archer-Daniels Midlands (a Rockefeller agri-business conglomerate) donations to the Democratic Party helped Bill Clinton get elected President in 1996. Don Tyson (the head of the international food conglomerate Tyson Foods) helped Hillary Clinton make 100,000 dollars on the commodities market. Worthen Bank Corporation loaned Bill Clinton money for his 1992 Presidential Campaign, etc.

Bill Clinton is a career politician. He has spent 16 years working as an elected official (he was Governor of Arkansas for 14 years). The following is a compilation of his activities:

He was a campaign worker for the Frank Holt for Arkansas Governor Campaign, a legislative assistant to Senator Fulbright of Arkansas, an assistant to a city councilman while attending Yale, a Democratic Candidate for a House Seat in Arkansas Third Congressional District, a director of George McGovern's 1972 Campaign for President in Texas, a professor of Law at the University of Arkansas in 1973 through 1976, a private practicing attorney in 1973 through 1976, a director of Jimmy Carter's Presidential Campaign in Arkansas in 1976, elected Arkansas Attorney General (he served in 1977 through 1979), elected Arkansas Governor (he served in 1979 through 1981 and in 1983 through 1992), a lawyer in the Law firm of Wright, Lindsey, & Jennings in Little Rock in 1981 through 1982, the Chairman of Southern Growth Policies Board in 1985 through 1986, Chairman of the Education Commission of the States in 1986 through 1987, a Member of the Task Force on Adolescent Education Carnegie Foundation, Chairman of the Democratic Leadership Council in 1990 through 1992, a member of the National Governors Association (vice chairman 1986, chairman in 1986 through 1987, executive commission, finance commission, human resources commission, international trade and foreign relations commission, rural development task force, education task force.), Chairman of the Lower Mississippi Delta Development Commission, Chairman of the Southern Growth Policies Board, elected President of the United States in 1992.

Hillary Clinton is an influential Arkansas attorney and assistant to Bill Clinton. She was a partner in the Rose Law Firm in Little Rock in 1977 through 1992. Because of this, she is closely associated with the David Rockefeller faction of the modern Standard Oil Trust. Winthrop Rockefeller's foundation and banks (Union National Bank of Arkansas and Worthen Banking Corporation) were/are clients of the Rose Law Firm.

The following is a compilation of her career:

She worked on the draft Nelson Rockefeller for President Effort in 1967.

She was an attorney for the Children's Defense Fund in 1973 through 1974, legal counsel Carnegie Council on Children in 1973 through 1974, counsel for the impeachment inquiry staff for the Judiciary Commission of the US House of Representatives in 1974, assistant professor of law at the University of Arkansas, a partner in the Rose Law Firm in 1977 through 1992, Chairwoman of the Legal Services Corporation in 1978 through 1981, on the Board of Directors of Wal-Mart Stores in 1986 through 1992, on the Board of directors of TCBY Enterprises Inc in 1989 through 1992, on the Board of Directors of Lafarge Corporation in 1990 through 1992, a lecturer at the University of Arkansas Law

School, author of Hand book on Legal Rights for Arkansas Woman. She was on the Board of directors of the Childrens Defense Fund, Child Care Action Campaign, National Center on Education and the Economy, Childrens TV Workshop, Public/Private Ventures, Arkansas Childrens Hospital, Franklin and Eleanor Roosevelt Institute. She was a member of the Commission on Quality Education Southern Regional Education Board, Chairman of the Arkansas Education Standards Commission in 1983 through 1984, the Head of National Health Care Commission.

### **Pat Buchanan**

Pat Buchanan is a media commentator for the Standard Oil Trust Media. He worked for Nixon when he was a lawyer for the Standard Oil Trusts.

He was instrumental in getting Nixon elected President in 1968. Working from Nixons Wall Street international corporate law office, he helped Nixon start his 1968 Presidential Campaign. Nixons law firm represented international corporations; some (if not all) were Standard Oil Trust companies.

In 1963, ex-Vice President Nixon sold his home in California and bought a condominium in the same condominium complex as Nelson Rockefeller. In June of that year, Nixon joined the Wall Street law firm of Mudge Stern Baldwin & Todd. After 6 months, he became a partner; and the law firms name was changed to Nixon Mudge Rose Guthrie and Alexander. Harsco Corp and Mutual of New York were some of the law firms clients. Nixon took the assignment of representing both corporations. He sat on the board of directors of Harsco Corp and he was a trustee for Mutual of New York. Mutual of New York was a Standard Oil Trust Corporation. E R Harriman (Avrerell Harriman, Harrimans brother) and Nixon were trustees of Mutual of New York at the same time. Harsco Corp is an international mining and defense contractor and is part of the Standard Oil Trust today. Robert C Wilburn sits on Harscos board of directors. He was the Vice President of Chase Manhattan Bank from 1972 to 1975.

In December of 1965, Buchanan went to Nixons law office in New York City and asked him for a job working on his 1968 Presidential Campaign. Nixon excepted, and Buchanan moved into an office in Nixons law firm. Working as Nixons Administrative Assistant, Buchanan got Nixons election campaign going. He helped Nixon prepare for his trip to the Middle East and Africa in 1967. He was Nixons Press Secretary and Speech Writer through the 1968 Presidential Primary Campaign.

After Nixon was elected President in 1968, Buchanan was appointed Special Assistant in the Nixon White House (his assignments were speech writer, and keeping the Presidents daily briefing book). In 1971, he declined his activities in the Nixon White House to discredit Daniel Ellsberg and to study

and write out the strategies the Democratic Candidates planned to use in 1972. After Nixon resigned, Buchanan became council to President Ford. In 1975, Buchanan returned to work for the major media until 1985.

In 1985, Donald Regan (CEO of Merrill Lynch, a Standard Oil Trust Corporation), suggested Buchanans appointment to the Reagan Administration. In 1985, Buchanan was appointed Communications Director and Speech Writer in the Reagan White House. He advised President Reagan to give aid to the Contras, veto the farm bailout bill, support runaway spending and cut taxes. Because Reagan followed these policies, we got the Iran Contra Scandal; loss of more family farms to large corporations; over 3 trillion dollar deficit in bond debt. A 3 trillion dollar bond debt meant the international bond trading houses (like Merrill Lynch) made a fortune trading bonds.

Buchanan is a long time journalist and commentator for the Standard Oil Trust controlled media. After graduating from Georgetown University in 1962 with a Master in journalism, he went to work for the St Louis Globe-Democrat as a reporter. After 2 months, he became an editorial writer. In 1966, he left the St Louis Globe-Democrat and began working for Nixons reelection campaign. After working in the Nixons and Fords White Houses, he returned to the media.

In 1975, he started writing a column for Special Features, a Subsidiary of the New York Times Company. In 1975, the New York Times Company was a Standard Oil Trust Company. Richard Lee Gelb (a Standard Oil Trust Company Director), sat on The New York Times board of directors. He, also, sat on Bristol-Myers board of directors. Bristol-Myers was (and is still) a Standard Oil Trust company. In 1975, James Hurlbert Evans sat on a Bristol-Myers board of directors. He was a Trustee for the Rockefeller Brothers Fund; a director of Citicorp, Citibank, GM, Met Life; and Chairman of Union Pacific.

The New York Times Company is still a Standard Oil Trust Company. Richard L Gelb still sits on The New York Times Companys Board of Directors. He is Chairman of Bristol-Myers Squibb Company (Squibb has been added because of a Merger). Louis V Gerstner sits on Bristol-Myers Squibbs Board of Directors. Louis V Gerstner is the Chairman of IBM. Pat Buchanan wrote for the New York Times Company for 3 years.

In 1978, he changed companies and started writing a column for the Chicago Tribune-New York News Syndicate. When he first began, his column appeared in 30 newspapers nationwide. When he left in 1985 to work for the Reagan Administration, it appeared in 138 newspapers nationwide. In 1978, Buchanan started a program on NBC Radio called Confrontation. After that, he started a TV program called After Hours on a Washington station. This show eventually became Crossfire on CNN.

CNN is a Standard Oil Trust controlled company. Time Warner owns 20% of Turner Broadcastings Stock. Turner Broadcasting is the parent company of

CNN. Time Warner is a Standard Oil Trust Company. Former Trade Representative Carla Hills sits on Time Warners board of directors. She also sits on other Standard Oil Boards of Directors: IBM, Chevron, etc. She is a former director of American Airlines.

When Ted Turner started CNN, his first advertising contract was with Bristol-Myers (a Standard Oil Trust Company). Their 25 million dollar contract made it possible for Turner to get financing to continue his new business. The advertising contract was given despite the loss of an RCA satellite that was vital to future operational start ups of CNN. When Satcom III was launched it became lost in space. Turner had signed a contract with RCA to use one of their transponders to beam his signal back to earth. With the loss of Satcom III, he had no way to get his new business started. Later RCA launched another Satcom III. That Satcom III is now owned by GE (RCA merged with GE). GE is a Standard Oil Trust Corporation.

In 1982, Buchanan became a panelist on the Washington talk show McLaughlin Group on NBC/PBS. PBS and NBC are controlled by the Standard Oil Trust. Sharon Percy Rockefeller (Jay Rockefellers wife) is on the board of directors of PBS. NBC is owned by General Electric.

In 1985, Buchanan became the Communications Director in the Reagan White House. When he became communications director, he discontinued his employment with Crossfire, Mc Laughlin Group, and The Tribune Media Services. After he left the Reagan White House in 1987, he reappeared on the McLaughlin Group and Crossfire and continued writing his article in the Tribune Media Services.

In 1988, he became a moderator of Capital Gang on CNN. In 1990 through 1991, he was editor in chief of the PJB-From the Right. He became a Presidential Candidate in 1991 and discontinued all his media activities. After the election he returned to Crossfire and Tribune Media Services in 1993. In 1993, he became Chairman of Buchanan and Co, Mutual Broadcasting Systems, The American Cause. He is the author of The New Majority, Conservative Voters Liberal Victories, Right from the Beginning, 90 America Asleep, Barry Goldwater, the Conscience of a Conservative.

In 1995, he started a talk show on KSFO San Francisco, Oakland, and San Jose.

Michael Reagan (Ronald Reagons son), also, has a talk show on KSFO. Recently Buchanan has appeared as a Presidential Candidate on NBCs meet the Press, on channel 5 and channel 46 this Morning Consumer Reports, Larry King Live, CNN, etc.



**Bob Dole**

Bob Dole is a career politician. He has spent 37 years as an elected official. He has been in the Washington legislature 32 years.

The Standard Oil Trust have him in their pocket. The following is an example:

The Archer-Daniels food conglomerate has supported Dole over the years. They have donated tens of thousands of dollars to his political campaigns. They donated \$100,000 to his foundation. Mrs Nelson A Rockefeller sits on Archer-Daniels board of directors. Bob Doles second wife (Elizabeth Dole) is a career bureaucrat. Her first Washington assignment was working the Johnson White House as a staff assistant in the Education Department. Her last appointment was Labor Secretary in the Bush White House. Since 1991, she has been the President of the Red Cross. While she has been president of the Red Cross, Archer-Daniels has contributed over one million dollars to the Red Cross. Elizabeth Dole bought a luxury condominium from Archer-Daniels in Bal Harbour Florida for the bargain price of \$100,000.

Robert Strauss (Clintons Ambassador to Russia) owns a condo in the same condominium complex. Strauss is Archer-Daniels attorney and sits on their board of directors.

The international corporations are backing Dole for the 1996 election. Bob Dole has been raising campaign funds in New Yorks financial district (The heart of the international corporations). He has been holding his fund raisers in the hotels owned by international corporations. These hotels receive massive government subsidies for the construction of their new hotels from federal and city governments. The San Jose Hilton (I am from San Jose) has received millions of dollars of subsidies from the local redevelopment agency. This is happening nationwide. In one fund raiser at the New York Sheraton (owned by the international conglomerate ITT), he was expected to raise over \$1.5 million. At The New York Waldorf-Astoria (owned by international conglomerate Hilton Hotels), he raised another \$1.5 million.

The following is a compilation of Doles long political career:

He won a seat in the Kansas House of Representatives; he served in 1951 through 1953. In 1953 through 1961, he practiced law in Russell Kansas.

He was elected Russell County Prosecuting Attorney; He served in 1953 through 1961. He was elected to represent Kansas in the US House of Representatives in the 87th, 88th, and 89th Congress. Nixon campaigned for Dole when he ran for Congress in 1964. Dole has been a US Senator from Kansas since 1969. He was the chairman of the Republican National Committee in 1971 through 1973. He ran for Vice President in 1976. He ran for President in 1980. He was Chairman of the Senate Finance Committee during the Reagan Administration. He was the Majority Leader of the US Senate in

1985 through 1986. During the investigation of the Iran Contra Affair, he helped the Reagan Administration coverup their involvement. He ran for President in 1988.

The following is a compilation of Elizabeth Hanford Doles long bureaucratic career:

She married Bob Dole in 1975. She was a staff assistant in the Education Department during the Johnson Administration. She was assistant director of Johnsons Committee on Consumer Interests. She stayed at that position through the Nixon Administration. In 1971, she was appointed Director of Consumer Affairs. In 1972, she was on the Nomination Committee of the American Stock Exchange. She was then appointed to the Federal Trade Commission by Nixon. She campaigned for Doles Vice Presidential Campaign in 1976. In 1979, she campaigned for the Dole for President Campaign. In 1980, she was Chairwoman for the Voter for Reagan-Bush. She was part of Reagons White House Transition Team. In 1980, she was appointed assistant to Reagan for Public Liaison. In 1983, she was appointed Transportation Secretary by Reagan. In 1988, she campaigned for Dole in the Presidential Election. She was the Secretary of Labor in 89 through 90. Since 1991, she has been the President of the American Red Cross.

### **Phil Gramm**

Phil Gramm is controlled by the Standard Oil Trust and international conglomerates; he has received backing from the Standard Oil Trust and international conglomerates. His wife works for the Standard Oil Trust. A Standard Oil Trust Company published one of his books, and a foreign corporation is publishing one of his books. He is a former Democrat that changed parties in the 1980ies.

International conglomerates are donating personal and money to Phil Gramms 1996 Presidential Campaign. His wife is an executive for a Standard Oil Trust International Conglomerate. For example, Gramm received \$5,000 from IPB (meat packing). IPB is owned by the international conglomerate Occidental. (Vice President Albert Gores father, Albert Gore Sr., is a director on Occidentals board of directors). Gramms campaign finance chairman, Alec Courtelis, and Gramms wife, Windy Lee Gramm, are on IPBs board of directors. Occidental is part of the Standard Oil Trust. Ray R Irani is the Chairman of Occidental. He worked for Olin Corp from 1973 through 1983; he was on the board of directors from 1980 through 1983. Olin is a Standard Oil Trust Company. William W Higgins and Jack D Kuehler sit on Olins board of directors. Higgins is a former Senor Vice President of Chase Manhattan Bank. Jack D Kuehler is a former Vice Chairman of IBM.

Like most international conglomerates, IPB has a policy of hire illegal immigrants and backing major political candidates in both the Republican and Democratic Parties. There has been two documented incidents where illegals have been hired by IPB this year. In May, two dozen illegal immigrants were arrested working for IPB contractors. In April, 35 illegal immigrants were arrested at a Minnesota IPB facility. Vice President Albert Gore's father, Albert Gore Sr., is a director of Occidental Petroleum's board of directors.

Gramm has been raising money in New York City's financial district: one of the centers of the international conglomerates. For example, Gramm held one of his fund raisers at the Waldorf-Astoria in New York City. At that one fund raiser, he raised \$520,000. Joe Fogg, a director of the international securities trading company Morgan Stanley & Co, was one of his guests.

The Waldorf-Astoria is owned by the international Hilton Corporation. The Hilton Corporation lobbies for redevelopment projects in major cities and is the recipient of major subsidies from local, state, and federal governments. In San Jose, my home town, the city council receives massive campaign contributions from a group that manages Hilton Hotels. In return for campaign contributions, the city council approved the construction of a high rise Hilton Hotel and subsidized its construction heavily.

CBS Corporation (A Standard Oil Trust Corporation) published a book written by Phil Gramm in 1980. Since this was while he was in the US House of Representatives, it appears that they violated campaign laws.

Praeger Publishing (a division of the international conglomerate CBS) published a book called *The Economics of Mineral Extraction* in 1980. The book was written by Phil Gramm and his two former associates at Texas A and M: S Charles Mauric and Charles W Smithson. CBS sold Praeger Publishing to the international publishing and communications conglomerate that is now Reed Elsevier PLC. Reed Elsevier is based in London England and operates world wide. Praeger Publishing is still publishing *The Economics of Mineral Extraction*.

Phil Gramm was a former economics professor at Texas A and M. While he was a Professor, he did contract research for private industry and the government interests. His consulting firm was called Gramm and Associates. Gramm was elected to the 96th through 98th Congress running as a Democrat. In 1983 he changed his party to Republican. With the backing of the international Oil, farming, and gas industry he was elected to the US Senate in 1984.

# THE ROLE OF THE CIA IN THE GLOBAL OIL CONSPIRACY

**BY JOE VIALLS**

**NEXUS MAGAZINE, DEC 1993 - JAN 1994**

*Joe Vialls is an Australian-based freelance journalist, with thirty years' direct experience in international military and oilfield operations.*

For decades the US Central intelligence Agency (CIA) has coveted global domination, not with the consent of the American people but rather by directing the actions of the American President as a child pulls the strings of a limp puppet. The term 'New World Order' was coined back in the late sixties by the CIA, not by a demoncratically elected leader of the American people. With the collapse of the USSR, the CIA saw its chance and pushed for global domination by manipulation of world oil resources. Its prime objective of developing the vast but little-known oil reserves in the British-dominated Falkland Islands had been frustrated since the early 1980s by oil prices too low to finance expensive Falklands exploration. Intending to 'bounce' oil prices high enough by forcibly reducing Middle East oil production, all the CIA needed was an excuse, which was 'miraculously' provided in 1990 by President Hussein of Iraq.

As American Ambassador to the United Nations and the Bush Administration's champion for compulsory US democracy, Thomas Reeve Pickering cut a dashing figure. Tall and urbane, he looked the perfect statesman as he hurled vitriolic remarks at the countries of the Middle East. There is little doubt that after stained exposure, most television viewers believed Pickering's carefully structured UN presentations.

Enter 'Thomas Reeve Pickering' into any counter-intelligence computer and the machine groans with agony as it struggles to flood the screen with an overwhelming mass of data. Tartania? Jordan? Washington's war on Nicaragua? Pickering was around for all of them and many more. He was even in El Salvador during the period the CIA supervised the 'Death Squads' responsible for the torture, assassination and disappearance of more innocent people than could be counted.

It is possible, though unlikely, that the numbers who died in El Salvador might have exceeded those who died at the hands of the Shah's hated 'Savak' secret police in Iran. As with the death squads in El Salvador, Savak had its torture and assassination techniques honed to perfection by the CIA.

Back in 1974 Victor Marchetti, formerly an Executive Assistant to the Deputy Director of the CIA, wrote of the 'New Order' then being planned at Langley headquarters. He explained in chilling terms why resignation was his only honourable choice:

*"And there was a diabolical invention that might be called a mini-cannon... There were a number of uses for the mini-cannon, one of which was demonstrated to us using an old army school bus. It was fastened to the gasoline tank in such a fashion that the incendiary projectile would rupture the tank and fling flaming gasoline the length of the bus interior, incinerating anyone inside. It was my lot to show the rest of the class how easily it could be done. It worked, my God, how it worked. It was, I guess, the moment of truth. What did a busload of burning people have to do with freedom? What right did I have, in the name of democracy and the CIA, to decide that random victims should die? The intellectual game was over. I had to leave."*

### **The Middle East**

Victor Marchetti resigned before the CIA decided to target the Middle East in its attempt to shift primary oil production from the Persian Gulf to the Falkland Islands. However, evidence the CIA maintained its vicious determination to murder random innocent victims by the thousand was soon to be provided in the Middle East with sickening massacres in both Iraq and Kuwait.

The CIA's first priority was 'putting men on the ground' in the Middle East as Intelligence operatives. Despite the sophistication of reconnaissance satellites, there was no substitute for human beings capable of infiltrating and undermining foreign government -- the Agency's normal method of operation.

From the outset, the CIA recognised two countries in particular would be very difficult to undermine easily: Iraq and Libya. The Agency infiltrated the Kurdish population in the north of Iraq but failed to gain the influence it needed. Sceptical readers should note that all Kurds inside Iraq are now known as "Freedom Fighters" while their brethren north of the border in NATO Turkey are labelled "Terrorists".

The governments of Iraq and Libya had managed to foil dozens of CIA attempts aimed not only at infiltration but also at assassinating the Iraqi and Libyan heads of state. One CIA report written in 1985 referred to a failed attempt to murder Colonel Al Qadliafi, stating the hit teams were inefficient. Ex-CIA Deputy Director John McMahon echoed the criticism.

## **The Gulf War**

If Middle East oil production was to be drastically reduced to increase world oil prices to the point where the Falklands oil reserves could be exploited, the timing of the CIA's Gulf 'war' was critical. Equally critical was the need for large numbers of sneak bombing attacks on Middle East civilians in order to shatter public morale as quickly as possible.

On 12 July 1990 during a small ceremony at the Lockheed "Skunk Works" in California, the last of 59 deadly F117A stealth bombers was handed over to its new owners: the 37th Tactical Fighter Wing, normally hidden deep in the remote Nevada desert at its secret 'black' air base at Tonopah.

Though the F117A was labelled the "Stealth Fighter" in order to deceive American taxpayers, it was no such thing. The F117A was designed using low-visibility data provided by the CIA as a black project killing-machine capable only of slaughtering under the cloak of darkness, very much in the tradition of assassins of old. Nor was the F117A very accurate: during the only operational mission before the Gulf debacle, two stealth bombers attacked an army barracks in Panama where both missed their targets completely. There would be many more 'misses' in the densely populated city of Baghdad.

Three weeks after the last stealth bomber flew into Tonopah, Iraqi forces invaded Kuwait and the 37th Tactical Fighter Wing was given a new commander, Colonel Alton Whidey. Within four hours of Whitley taking command, the stealth bombers were ordered to fly to Saudi Arabia via Langley Air Force Base in Virginia under cover of darkness. The United Nations had not yet responded to the Iraqi invasion of Kuwait, but the stealth bombers were already being positioned for their attacks.

The CIA was well aware of President Hussein's armed forces massing to the north of the Kuwaiti border during 1990. Despite the fact it had many days of advance warning, the CIA failed to tell the Kuwaiti government of the forthcoming attack. With all the sophisticated communications at its disposal it was a truly damning omission that escaped Western media attention, pointing directly at CIA manipulation of the invasion itself.

## **Cia Manipulation Of The Media**

Millions of television viewers watched the most damning evidence of CIA premeditation but most failed to recognise it. Though European troops were rushed to the Gulf in out-of-date ill-fitting desert camouflage, there was no such problem for the US forces. Despite the fact America has never fought a large-scale desert campaign, nearly a quarter of a million US troops arrived in Saudi Arabia wearing well-fitting post-Vietnam-pattern desert camouflage. Someone somewhere had done a vast amount of covert advance planning and

purchasing for the desert campaign, because no nation on Earth keeps a quarter million uniforms on hand for every different climate zone in the world.

From that point forward, white became black and black became white -- courtesy of the CIA "Psychological & Paramilitary Staff" unit operating under the direction of the Deputy Director Plans (DDP). For decades the unit has specialised in deception and abuse at the psychological level, fitting it perfectly for the role of turning both President Hussein and Colonel Al Qadhafi into 'non-democratic dictators' in the eyes of the West.

The most memorable (and successful) of the ploys used was to turn President Hussein into the man who 'gassed his own Kurds' at Halabja. The same devastating images of dead women and children lying in the streets were shown thousands of times on all Western television channels, placing President Hussein well beyond Western 'rehabilitation' under any circumstances.

Unfortunately the entire exercise was a complete lie. The CIA knew very well that a February 1990 US Army War College report concluded Iraq was not responsible for the Halabja attack, stating "that it was the Iranian bombardment that had actually killed the Kurds". The War College findings were hardly surprising: the Kurdish people of Halabja were killed by a war gas known as Phosgene used by the Iranians but not the Iraqis. Though Iraq did use war gas on the battlefield, it was Mustard, an entirely different chemical which causes death in a visibly different way, enabling US Army chemical warfare experts to easily identify the attack as Iranian in origin.

Though many readers may say "So what?", the distinction is important in identifying CIA media techniques used to deliberately distort the perception of the Western public. When the US Administration was looking for an excuse to use ground forces to finish off the people in Kuwait, the CIA flashed a story round the world about Iraqi soldiers ripping newborn Kuwaiti babies out of their incubators and throwing them on the floor. As with the Kurds of Halabja the story was proved totally false, though not before US tanks had buried 8,000 Iraqi soldiers alive in their bunkers and destroyed half the ground installations in Kuwait and southern Iraq. Disinformation is critically important to the CIA, for without it the Agency would be unable to whip up sufficient public outrage to justify its savage attacks.

For an alert Western public there were other indications that neither President Hussein nor Colonel Al Qadhafi were dictators who habitually murdered their own citizens. If that were the case, there would be no point in both of them training huge numbers of doctors, for doctors cure people -- they do not kill. While Saudi Arabia and Great Britain (two of the coalition partners) have only one doctor for every 4,321 and 4,632 people respectively, Iraq has one doctor for every 2,303. Colonel Al Qadhafi has trained a staggering one doctor

for every 757 people. Facts like these were considered counter-productive to the CIA's aims and were ruthlessly suppressed.

Boosted by CIA lies and disinformation, the Bush Administration pushed with indecent haste for military action against President Hussein. After successfully applying pressure to the United Nations Security Council, the Bush Administration ordered its stealth bombers to attack the capital of Iraq instead of the forces occupying Kuwait. Under cover of darkness during the night of 16-17 January 1991, the first F117's flew out of Khamis Mushait in southern Saudi Arabia to start the killing in Baghdad. The 'black' stealth bombers were to fly a total of 1,271 missions in less than six weeks, dropping more than five million pounds of bombe on populated areas.

The total bombardment was awesome and sickening: 88,000 tons of bombs, 97% of which flew wide of their targets, ripping more than 70,000 innocent women and children to bloody shreds and maiming countless thousands more. Sadly, the Iraqi dead were merely a sideshow for the primary CIA objective of controlling world oil reserves on a permanent basis.

Around 16 February 1991, American AV8B Harrier groundattack jets started flying with wing-mounted napalm pods. Less than a week later, on 22 February President Bush accused Iraqi forces of lighting 140-plus oil wells in Kuwait. If the Iraqi forces had done so, they managed it while under continual attack by about 2,500 coalition aircraft-an act of crass stupidity or outstanding bravery in the face of stupefying American firepower.

Somehow the Western media missed the point that napalm burns at a temperature high enough to melt the side-pipes on oil well-heads and is capable of setting fire to the crude oil which then blasts out under high pressure. Most of the public also remained unaware that CIA pilots are cross-trained to fly a large variety of both military and civilian aircraft. During this precise period Kuwaiti Air Force pilots were grounded in Saudi Arabia on the orders of the American Commander in Chief.

It is left to the reader to speculate why the US High Command ensured that no native Kuwaiti pilot be allowed to fly over his own oil fields during this specific phase of the operation.

Within 24 hours of the Bush accusation, the Iraqi government denied setting fire to the oil wells and urgently called on the United Nations Security Council to send a team to "investigate the destruction of non-military installations in Kuwait" -- a curious response from the Iraqi government if it was guilty of the alleged crime. The American-dominated Security Council dismissed the request out of hand.

When the Iraqis retreated from Kuwait, American forces violated mutually agreed cease-fire terms, shooting more people in the back with radioactive 30 mm Depleted Uranium (DU) shells than Adolf Hitler could have imagined in his



most vivid dream. Unluckily for its human targets, the CIA was out to prove Adoff Hitler a mere simpleton with a strictly limited imagination.

American Fairchild A10 "Thunderbolt II" ground-attack jets criss-crossed the highways of death in Kuwait, spitting radioactive 30 mm shells at the rate of 4,200 per minute per aircraft. Anyone left alive after the strafing runs, the CIA reasoned, would probably die a terrible death much later from the effects of toxic uranium poisoning. Over time, the same highly toxic radioactive waste would slowly kill large numbers of the civilian population in both Iraq and Kuwait. Though larger 120 mm DU shells were used by battle tanks, the US administration claims 'only' 5,000 of the 120 version were fired.

There is only one gun capable of firing the special high-velocity radioactive 30 mm DU shells: the GAU-8A seven-barrel "Avenger" Gading cannon, specially designed for the Thunderbolt. Even at a range of two miles, the 30 mm DU shells are known to be travelling at almost one mile per second, hitting each target with almost half a million foot-pounds of energy. With impact forces that high, very few 30 mm DUs ricocheted and stayed in one piece, most exploding into uranium dust which was strewn far and wide across the land.

The awesome Avenger Gatling is capable of firing depleted uranium at the rate of nearly 12 tonnes per minute per gun. Small wonder the US administration remains acutely anxious that the total number of 30 mm DU shells fired should remain "Classified".

Someone somewhere had done a vast amount of covert advance planning and purchasing for the desert campaign, because no nation on Earth keeps a quarter million uniforms on hand for every different climate zone in the world.

### **The Oil Men Take Control**

Shortly after driving the Iraqi forces out of Kuwait, the American government handed total control of Kuwaiti oil operations to Bechtel Corporation-an American multinational giant originally founded by CIA Deputy Director John McMahon. Former Bechtel corporate presidents and vice presidents include George Schultz and Caspar Weinberger. It was an odd choice. Bechtel excels chiefly in the area of civil construction. Unfortunately the problem it faced was 'upstream' oil technology involving oil well blowouts raging at up to 11,000 p.s.i.

By June 1991 the coordinator of the well-control teams, T.B. O'Brien of Midland, Texas, complained of Bechtel slowing down the rate of damage control by going through a long slow bidding process for equipment that could be had 'off the shelf' in Dubai, a short distance away down the Persian Gulf.

"In the meantime, about US\$40 million to US\$50 million in oil burns a day, but nobody looks at that," Mr O'Brien said. "These things are not an emergency to them."

After months of increasing pressure from world environmentalists about the smoke then circling the globe at high altitude, there was an apparent acceleration in well control efforts. On 6 November 1991, Sheikh Jabir-al-Ahmad al-Jabir al Sabab was shown on television throwing a lever that put out the last of the fires which had raged since February. It was a public relations masterpiece and most world environmentalists immediately stopped worrying about possible global environmental effects. They were wrong to stop worrying, for their worst nightmares are probably yet to come in the Falklands.

### **Oil Discovered Under The Falklands**

During late 1981 an obscure document was circulated around a small select group of Western oil multinationals. The data it contained was staggering and details swiftly leaked. In a recently completed comprehensive seismic survey of the Falkland Islands continental shelf, realistic estimates indicated oil reserves more than ten times larger than those in Saudi Arabia. For anyone with the wealth to exploit the reserves, the magnitude of the prize was almost beyond comprehension.

That the seismic was accurate was proved beyond doubt by the mid-1980, by which time Argentina had proven reserves of more than four billion barrels on its Patagonian coast directly opposite the Falkland Islands. With the continent shelving downwards out to sea, calculations indicated Falkland Islands reserves easily as massive as those predicted in the 1981 document.

During 1982 many Britons wondered aloud at the sheer compassion of their government which sent an entire battle fleet to evict the Argentines who, it was rumoured, were indecently assaulting a few hundred Falklands sheep farmers. It was democracy at its best and countless thousands of patriotic Britons cheered the QEII as she cleared the harbour at Southampton laden with troops for the fight in the South Atlantic.

Democracy? The British government had probably forgotten the sheep farmers a generation before but it knew about the oil reserves, as did the Argentines who managed to obtain a copy of the seismic report. Those oilmen who knew of the seismic report watched the patriotic fervour with amazement but said nothing. If the British public really wanted to believe the Thatcher Government would send a battle fleet 8,000 miles to protect a few farmers, it was not their job to disillusion them...

The American and British governments were excited at the prospect of total oil self-sufficiency and the resulting ability to bypass the Middle East completely for their energy needs. But what if the nations of the Middle East

tried to compete with them? The shorter shipping distance from the Persian Gulf to most world markets would still undermine prices. Clearly strategic controls had to be placed on the Middle East first.

The problem the British government faced was twofold: the Falklands were so far away that Britain alone could never hope to explore without the assistance of the Americans; secondly, the ready availability of Middle East crude at low prices would make exploration a financial impossibility. Despite the predictions of some analysts during 1981 that crude oil prices might rise as high as \$80 per barrel by 1985, there was no way of telling if those predictions would become reality. (By 1985 oil prices had in fact slumped dramatically to \$10 per barrel, well below the \$28 minimum needed for Falklands exploration.)

Proof the Arab nations had 'noticed' the Falklands survey was provided in 1982 when OPEC suddenly kicked the bottom out of the price of crude oil. For nearly ten years following the famous price-hike of 1973, western oil multinationals had been using their windfall revenue to build many more oil rigs to drill more and more wells. So frantic was the activity that the total number of rigs drilling under western multinational control rose from around 1,500 in 1973, to just over 4,600 by late 1981.

Disaster swiftly followed the 1982 oil price collapse with more than 3,000 western drilling rigs suddenly idle due to a lack of funds. In other words, the number of active drilling rigs went into reverse gear, dropping from 4,600+ down to 1,600 in less than nine months from late 1982 to mid-1983. For the oil industry it was a total nightmare with drilling contractors going broke overnight, while hundreds of multimillion-dollar oil rigs sat quietly rusting in the deserts and mountains.

If evidence was ever needed proving the size (and danger) of the Falklands reserves, this was it: the nations of the Middle East flooding world markets with crude oil from massive over-production, and halving their own revenues in order to halt western moves to exploit the massive South Atlantic oil fields. The size of the catastrophe for the western oil multinationals was barely noticed by members of the public, who responded with ill-concealed glee to cheaper petrol prices at the pumps.

Vast oil reserves in the South Atlantic, initially merely tempting, soon became a strategic imperative in the minds of the western oil multinationals, frustrated by their continued inability to raise world oil prices. Reducing Middle East production to earlier, much lower levels was the only way to achieve the objective, but how could it possibly be done? After all, the Arab countries might object to any production controls placed on them. Personnel at CIA headquarters in Langley went to work eagerly searching for the solution.

And so it was that a mere ten years after the Falklands seismic survey of 1981, the firefighters walked away from still-smoking oil well-heads, leaving

behind them two shattered Arab oil-producing nations: Kuwait and Iraq. Not bad for a first strike.

### **Libya Is Next**

Combined Arab output before the Iraqi slaughter began was about 13.17 million barrels per day, excluding Iran. Within 40 days both Kuwait and Iraq had stopped production completely, theoretically reducing the daily output by 4.36 million barrels, or 33% of balanced Arab oil output.

The world barely noticed as Saudi Arabia took up the slack and increased output to compensate for lost Kuwaiti and Iraqi production capability. The CIA strategic planners noticed though. What they had done was reduce the number of Arab oil-producing nations by two. If they could also eliminate Libya there would be another fall of 1.36 million barrels per day, creating a further drop in balanced Arab oil output equalling 10.3%. With all three countries wiped out, the total drop would be more than 43% -- nearly half of the total. The three other Arab producing countries considered to be 'friendly' to the US administration could be left for treatment at a later date, as could Iran.

### **Conning The Greenies**

The masses of environmental scientists who swarmed to the Gulf to examine the carnage were skillfully shown slick damage in the Gulf, mines on the beach at Kuwait, smoke in the sky and some low pressure blowouts in the Burgan field. None, including Greenpeace, was allowed to 'stray' into the real problem areas to the north of Kuwait city, or the areas of southern Iraq subjected to carpet-bombing by American B52 heavy bombers from Diego Garcia in the Indian Ocean.

Blowout pressures in the north were up to ten times as high as those in Burgan field-a very good reason for keeping unwanted spectators away. John McMahon's old company, Bechtel, subtly directed the flow of traffic away from the 'dangerous' areas. Huge lakes of crude oil, no longer burning to atmosphere, increased in size to the point where some roads were impassable.

Within days of Sheikh Jabir-al'Ahrnad al-Jabir al Sabah throwing the lever that 'capped' the last of the burning wells, the British World Conservation Monitoring Centre commented on the blowing wells the media cameras somehow missed: "Burning wells cause less pollution damage than non-burning gushers."

It was a factual statement, entirely accurate but understating the case. When an oil well blows Out the primary task is to stop the flow of oil from the underground reservoir. Most wells that blow out but fail to light spontaneously are lit as quickly as possible by well-control specialists, in order to keep the

volatile oil and explosive gas away from workers in the immediate area. Failure to light the well swiftly can lead to a situation where lakes of oil entrained with explosive gas pose a deadly risk for the well-control specialists themselves.

How were the specialists to control rogue wells surrounded by huge oil lakes, growing larger all the time as they were continually fed with more underground oil and gas? The British *New Scientist* of 9 November 1991 painted a grim picture of the massive problem the environmentalists had chosen to forget:

*"The lakes vary in size and depth but are usually no more than a metre deep. In the northern oilfields, small lakes have to form rivers that stretch for many kilometers."*

Horrifying stuff, and it got worse. Middle East contacts advised that one of the lakes measured about 8 kilometres by 5 but was 'only' about a metre deep. Only? The capacity of that lake alone to a depth of one metre is 230 million barrels. How many lakes are left, what is their combined capacity and how many rogue wells are still feeding them? Alas, the CIA and NSA are being coy and sitting on the satellite images so details may be withheld until a complete cure is impossible. One thing is certain: the western public will never be told the truth.

### **The Human Price Of Oil**

From the CIA viewpoint Kuwait and Iraq were oil cripples, with savage sanctions 'punishing' the entire civilian population of Iraq by slowly starving women and children to death, while deadly toxic uranium dust worked even more slowly in the south of Iraq and in Kuwait. Put simply, the CIA was responsible for the clearest case of genocide since Pol Pot butchered more than a million unarmed civilians in Cambodia during the 1970s.

Next the CIA turned the United Nations Security Council through about five points of the compass and pointed it at Libya. The third card in the deck was scheduled to fall before the November American presidential election. That way there would be a double bonus with decreased Arab production and more 'gung-ho' votes for the hawkish extremists. President Bush was starting to need votes badly. During the US slaughter of 70,000 innocent Iraqi women and children, his popularity rating rose as high as 90% but the glitter and glory was fast wearing off as decent Americans became aware of the tragic events in the Middle East.

Once again the tall, urbane Thomas Reeve Pickering went about his job with astonishing vigour, drumming up support for full-blown sanctions after failing to convince Libya that it should meekly hand over its citizens for a 'fair' trial in America or Scotland on the accusation of bombing Pan Am 103. Seemingly the Western Intelligence agencies had suddenly found critical

evidence that Libya, rather than new coalition partner Syria, was responsible for the outrage. The Security Council was stretching the public's imagination to bearing point.

There is a very strong possibility neither Libya nor Syria was directly responsible for the downing of Pan Am 103. The timing of the crash indicates it may have been an Iranian order that sent Flight 103 earthwards after the downing of an Iranian Airbus, carrying a full load of women and children, by the USS Vincennes.

At the time of the Airbus crash the US Navy forgot to explain to the media that even if surface-to-air missiles are fired by mistake, every one of them has a 'self-destruct' charge that can be detonated by remote control in a split second. No explanation was offered as to why the missiles were not detonated long before they struck the Airbus. The Iranians must have been upset by the slaughter of their innocent women and children, and by the presentation of a special medal to the captain of the USS Vincennes by President Bush.

The Security Council, in its haste, completely ignored such trifling matters and pressed ahead with its charges against Libya. Once again using the electronic media to maximum effect, Libya was slowly but surely turned into a 'guilty terrorist state' in the eyes of the television viewers. No matter the entirely correct procedures that Libya used to respond in terms of international law: the Security Council was going to 'punish' the country and its leader-just as the US had in 1986 on a trumped-up charge when it bombed Tripoli and Benghazi, leaving trails of murdered women and children strewn across both cities.

Apparently the 1986 sneak attack did not do enough damage in the eyes of Comte de Marenches, then head of the SDECE, the French version of the CIA. The Count berated the Americans for their inefficiency with staggering simplicity and arrogance: "Why, instead of killing a few women and children, did they not bomb the oilfields?"

Examining the massive levels of bomb damage and toxic uranium dust in Kuwait and Iraq, it seems entirely possible the CIA took the Count's rebuke to heart and was trying to atone for its 1986 'failure' in Libya. Worse still were grim pronouncements from the Security Council that "the use of force against Libya has not been ruled out".

The threat was obvious: another 88,000 tons of bombs with an accuracy of 3%, more than 70,000 dead innocent Libyan women and children, total destruction of the Libyan civilian infrastructure, plus starvation and death through savage sanctions -- a high price to pay for following international law to the letter as Libya undoubtedly had.

As with most ideas hatched by psychotic megalomaniacs wishing to control the world by force, the Falklands game plan came unstuck. The CIA

managed the massacre stages quite well (it always does) but flunked on the oil price increase needed for an effective transfer from Middle East to Falklands crude oil. Although it was openly reported on 7 December 1991 that British Petroleum, Shell and Occidental were expected "to bid for rights" in the Falklands, the oil price was already unstable again.

Too few people realise just how dangerous the CIA really is. If the Falklands scenario ever came to pass it would be the Western public who would ultimately have to bite the bullet, paying massive prices for Falklands crude oil in order to please an out-of-control US intelligence agency that is accountable to no one including the President of the United States.

Nor would the environmentalists fare well. The Falklands lie in one of the most environmentally sensitive and unspoiled areas of the globe. The South Atlantic is an extremely dangerous place to drill, with complete exposure to huge swells from the Southern Ocean and no shelter at all. There is no doubt that weather alone would easily exceed the structural design limits of all but the most sophisticated state-of-the-art offshore drilling rigs. The level of devastation created by the oil multinationals operating completely outside the scrutiny of environmental watchdogs like Greenpeace would be obscene in its totality. Who could possibly afford aircraft with the range to keep an eye on them? The simple answer is no one could.

During the last two years Kuwait has managed to produce a little oil, Iraq has exported some through Turkey, and certain European countries have so far managed to stop an all-out oil embargo against Libya. Overall, these factors have helped to push oil prices substantially lower than they were just after the destruction of Iraq and its people during 1991--certainly to the point where large-scale exploration of the Falklands continental shelf would be a very high-risk financial venture.

Just how long that situation will last is uncertain, with the US now once more pushing hard for an oil embargo against Libya--an objective it will continue to struggle to achieve because the Falklands crude oil is a prize too heady to leave alone forever. In the years to come, the CIA might lose patience and start sending out 'friendly' probes towards Argentina. Exploration of the shelf from the Argentine mainland would cost much less, and would allow the US oil multinationals direct access without having to bother too much about junior partner Britain.

It has long been recognised the CIA has a considerable amount of blood on its hands, but never more so than now. Back in 1963 President John F. Kennedy acknowledged the dangers and vowed to "shatter the CIA into a thousand different pieces." Before the end of that year one of the greatest of all American presidents lay dead, the back of his head blown off by a high-velocity bullet fired by a marksman positioned ahead of his limousine.

Perhaps there is an American citizen out there with the sheer determination and resolve to complete what President John F. Kennedy vowed to do in 1963.



## **SUPPRESSION OF FREE ENERGY DEVICES**

### **INVENTORS & MOTHER EARTH BEWARE!**

**BY JOE MACKEM**

---

There has been a revived energy revolution movement going on around the world the past 20 years that has not been covered or reported by mainstream press, establishment scientific journals or university research publications.

Most of the discoveries have been made by curious, ingenious minds, who on many occasions have observed experimental results in cold fusion, superconductivity, and magnetic motors which appear to violate present laws of physics, chemistry and electrodynamics. A term has been used to describe such phenomena, is called over-unity energy or free energy, which in many cases means getting more energy out of a system or reaction (magnetic motor or cold fusion reaction) than appears to be put into it. A better explanation is that excess energy is being accessed from as yet not completely explained source. (Note: An atom bomb is an over-unity device which gets a tremendous amount of dirty energy out, in the form of harmful radiation, than is needed to trigger the reaction.)

The first question that usually pops into a skeptic's mind is that if the technology is for real and discoveries have been made, such as Pons & Fleischman's cold fusion cell or Rory Johnson's fusion magnetic motor, why has it not been reported or mass produced for use by our energy-hungry world? The answer is suppression. What do we mean by suppression? Suppression can be an active type -- where a corporation or oil company or OPEC, who does not want the invention marketed, will blow up or destroy the lab and the invention and threaten to kill the inventor if he again attempts to market the revolutionary device. The other type of suppression is the passive type where a competing company, who has big bucks, such as some of the major oil companies, will come in and buy out a patent with no intention of bringing it to market until the demand for oil greatly exceeds the supply and gas prices soar, then they will start marketing a 100 mpg carburetor fir ICE (Internal Combustion Engines).

Other types of passive suppression include universities which are receiving big funding from oil or nuclear establishment sources, refusing to do research, or muzzling bright professors (by withholding tenure) from publishing theories and results as to the what, how's, and whys of these over-unity motors

and cold fusion reactions. Or the example where a Patent office refuses to grant patents in revolutionary technology, claiming perpetual motion machines, as they see them, aren't patentable, or if they are patentable, that they can place a secrecy order or gag order on the patent, which prohibits the inventor from disclosing any information to anyone for such disclosure might be detrimental to national security. See Appendix 2

The following suppression stories you are about to read are true, to the best of our knowledge, but the names and places have been changed to protect the innocent. This information will hopefully give you some reasons why this over-unity technology has not reached worldwide attention or use. Perhaps perpetrators of this much-needed new energy technology suppression will consider reversing their policy and incorporate this technology into their business structure for a future profitable enterprise. Such technology can restore Mother Earth, which seems to be in great agony right now, with hot fusion, (nuclear power plants), blowing up, and/or radiation byproducts seeping into water tables in the Russian Arctic or at Hanford, Washington, where radioactive waste seems to be seeping into the Columbia River. In the case of oil spills such as the Exxon Valdez tanker spill, or the U.K. oil tanker spill, these major environmental accidents have destroyed pristine fish and wildlife breeding grounds. What is good for the multinational oil companies, OPEC, and nuclear power plants may not necessarily be good for Mother Earth, the nation's human and animal health, or emerging countries whose energy resources are being exploited and their environment, such as the Russian Arctic tundra and South American jungles, destroyed for our short-term, consume-consume energy fling.

For these reasons, the development of energy technology has really gotten the attention of the ingenious, non-conformist inventors. Pioneers they have admired include Nicola Tesla, John Keely, T. Henry Moray, and others. Two primary areas of R&D have been targeted: 1) clean cold fusion as opposed to dirty hot fusion (nuclear energy), and 2) zero point magnetic energy. Again, these technologies have been actively and passively suppressed. The following documented stories will, hopefully, give you some specifics of suppression.

1. In the late 70's a brilliant inventor, Rory Johnson of Elgin Illinois, invented a cold fusion, laser activated, magnetic motor that produced 525 HP, weighed 475 lbs, and would propel a large truck or bus 100,000 miles on about 2 lbs of deuterium and gallium. This was years before Pons & Fleischman or Dr. James Patterson entered the scene with their cold fusion technology. Rory Johnson was in the process of negotiation with the Greyhound Bus Company to install this revolutionary motor into a few buses to demonstrate the fuel savings, maintenance reduction, and hence a more profitable balance sheet for Greyhound.

The mistake Rory Johnson made (little did he know that OPEC was keeping close track of any future competition to their oil business and that he was number one on the hit list) was to actively publicize his advanced fusion-magnetic motor in many magazines, telling of his plans to manufacture and distribute this revolutionary motor nationwide. ( I have even talked to a few people who had signed up for a distributorship). Coincidentally, after agents of Greyhound tried to get in touch with Rory Johnson after a year of no contact, they were notified that Rory had passed away unexpectedly. A man of robust health in his early fifties dying?! It was later learned that for some threatening reason, Rory moved out of his laboratory unexpectedly in the middle of the night with all his motors and technology and moved to California before he died.

Another astounding development that surfaced was a restraining order, or gag order, by the U.S. Energy Department had been placed on Rory's Company, Magnatron, Inc., prohibiting him from producing the Magnatron engine. See Appendix 1 - a letter from Minnesota State Senator Marion Manning to U.S. Senator from Minnesota Dave Donenberger inquiring as to why our government would place such a gag order on Mr. Johnson. Isn't this the land of the free market economy? Apparently not. Something seems a little strange about this whole incident. Are the oil cartels dictating energy policy to the U.S. Government? Read on.

Remember Ruby Ridge, recently adapted to a TV movie where over zealous U.S. agents killed Randy Weaver's wife and son? Well at the same time of this FBI siege, another inventor, at that very time, happened to be living and working on an advanced zero point energy device in Northern Idaho.

As the story goes, (told first hand to me by the investor), the investor was coming to visit the inventor who had just made a breakthrough in a free energy device, but made the mistake of publicizing his breakthrough on a local TV station. The day before the investor arrived, two government agents broke into the inventor's home, surmising that both the inventor and his wife were away. It just happened the wife was still at home and was very familiar with the use of a hefty handgun. At point blank range, she held the agents at bay inside her house while she debunked their excuse that they were cable TV repairmen checking out their cables lines. If it wasn't for the siege of Randy Weaver at Ruby Ridge, who knows what else would have happened that day. Some comments from this inventor will appear near the end of this article.

By the way, whose side is our government on? It appears that the big money interests, oil cartels, nuclear power companies have control of it. These big powerful corporations don't want any competition. They hoard most of the research funds on not necessarily new or revolutionary technology. It appears it isn't what's in the interest of National Security or Balance of Power in the Middle East, but what is in the best economic interest of the multinational

corporations. A classic example is the government-funded hot fusion reactor at Princeton's Plasma Physics Lab. The "powers that be" know there are cleaner, safer and cheaper ways of producing nuclear energy, like bombarding lithium with protons -- known since 1932, but has been kept secret and kept out of college textbooks. Read "The Fifty Year Nuclear War" by David Sereda in the Jan/Feb 1996 issue of Perceptions (310\_ 313-5185 for more eye-opening details. This is a classic example of passive suppression of new, clean, economical alternate cold fusion energy.

Now for some real active suppression! About 10 years ago, some very clever backyard inventors took a magnetic generating fly wheel off a Model T Ford, placed stationary magnets in a spiral arrangement to the outside, and developed a self-generating motor-generator. The motor-generator (using the pulsed varying distance magnetic spiral principle), continually produced 1600 watts of power with no outside power input. They demonstrated the generator at UCLA, which confounded the professors, students, and other onlookers. Evidently there were some heavy-handed corporate types in the audience, because the inventors never made it home from the demonstration. The two demonstrator-inventors were found dead along the highway, and the trailer with the generator inside was missing.

Now the Japanese apparently have the technology which is referred to as the "magnetic Wankel" motor

### **Magnetic Wankel Motor**

Yasunori Takahashi, a famous Japanese inventor who developed the beta video tap, has retrofitted his newly developed super powerful YT magnets into a 15 HP Magnetic Wankel motor scooter and claims he can get 15 HP from a few amperes of electricity input. Now when the Japanese start to import these scooters -- into the U.S. -- (if our U.S. Government will allow it), there goes our further balance of payments deficit to Japan. Incidentally, rumor has it that Mazda tried to import the Magnetic Wankel motor in a Mazda several years ago but was refused entry by the U.S. Government, just as was a super-high-mileage, gas-powered Honda was kept from entry into the U.S. a few years ago by our government. Let's hope U.S. Government policy changes, before it becomes more bankrupt due to the increasing balance of payments deficits with Japanese manufacturers and foreign oil companies due to the wasteful, gas-guzzling technologies we have come to embrace as the American Way.

Now for another story on suppression which includes a black helicopter incident.

2. Someone presented a video tape of an advanced tachyon generator which accessed tachyon waves (extremely short waves - like cosmic waves). It not only produced excess energy, but it also exhibited time-warping

characteristics. This presentation was made at an annual Tesla conference in 1993, without the inventor's permission. The video tape was shown on a Friday afternoon, at a location 3,000 miles away from the inventor's home. The very next day, U.S. Government agents were knocking at the inventor's door wanting to see the device. He kindly told them no thanks, and the very next day a black helicopter was hovering overhead taking pictures of the inside of his house. The black helicopters and possibly even satellites apparently now have the capability of photographing every item inside a building.

A similar situation occurred with another inventor. He was experimenting with an advanced form of plasma discharge energy. The very next day, while he was at work his neighbors told him later there was a black helicopter hovering over his house for several hours, evidently taking pictures of this technology in his basement.

Another story: In 1995, a man named Volcheck of Grand Coulee, Washington, made a trip across the United States and back in a car powered by a special gas he developed that had unusual expansion properties. He claimed to have obtained the formula from some unpublished notes of Leonardo Da Vinci.

He says the gas expands enormously at about 395 degrees Fahrenheit to 450 pounds pressure. In other words, from approximately 390 to 395 degrees Fahrenheit, the gas expands from a volume of one unit to a volume of 10,000 units. He used this gas in a modified Franklin aircraft engine which behaved more like a steam engine. He never refueled during the trip, consuming \$10 worth of this special gas.

Soon after his return, some congressmen invited him back to Washington, D.C. for a special hearing and congratulatory meeting. While he was gone, Federal Marshalls or a S.W.A.T. team forced entry into his shop, confiscated or destroyed his record-setting car, plans, components, special gas containers. They subsequently told him to forget any more projects like this.

Read on. An inventor and a Ph.D. Electrical Engineer from one of our prestigious universities had made a breakthrough on an over-unity motor and hired a hall in a mid-sized town in the U.S. to show off their new discovery. It was an impressive demonstration. What happened next was also (suppressive) impressive. A black van, with windows that you couldn't see into, staked out their lab. Three weeks later, a S.W.A.T. team of six kicked down the lab door, and with axes, destroyed half a million dollar's worth of equipment in one-half hour. They forced the inventors onto the concrete floor, face down, and held their heads against the concrete, until bleeding occurred and the equipment was destroyed. They said they were looking for the nuclear source. They had no warrants, just "S.W.A.T. TEAM" printed on the backs of their brownish uniforms. The inventors were told to cease all further

development, and the apartments one of the inventors owned were condemned. The tenants were ordered to leave and the Ph.D. Electrical Engineer is still being harassed by the IRS.

The late Floyd Sweet developed the vacuum tube amplifier, an advanced solid-state, magnetic over-unity device. In the late 1980s, a man claiming to represent a conglomerate, met up with Sweet and told him he did not want the VTA to come onto the market at that time and said, "It is not beyond possibilities to take you out of the way," (quoted from Pate 78 of *The coming Energy Revolution*, by Jeans Manning, 1996, Avery Publishing Group. There are many other suppression incidents in her very informative new energy book, ISBN 0-895290713-2 (\$12.95)

### **Some Comments On Suppression - by a Free-Energy Inventor (anonymous)**

"The Powers that be made me angry! I do not like my telephone tapped, tracers put on my automobiles, round-the-clock surveillance, and my mail messed with. I do not like the 'little' things that 'happen' around me."

"The only reprieve I got last summer was when the agents watching me were pulled off to join the siege of Randy Weaver." Can you imagine 400 men surrounding a man's cabin, killing his wife and only son, because he wanted to be left alone? It's a long story, but that's what it amounts to.

"I have gone so far as to set up a 'dead man' procedure, so if I become unable to profit from my inventive thinking, complete copies of my notes will be sent to selected individuals."

"I don't really see where it is such a big deal. The Powers That Be can simply invest in my technology, or other's like it and make as much money as before. Suppressing these technologies benefits on one. Unlimited energy would potentially make this planet a prosperous paradise."

"The United States patent office has a policy prohibiting a patent on a perpetual motion machine. This policy is a case in point of what happens when you have too much government. Why make a policy against something that you believe impossible? A second irony to the situation is that the patent office already allows patents on devices that don't work! So why would they care if a perpetual motion or an over-unity machine works or not? Their real function is simply to record the patent as the inventor applies it. If it works or not really isn't their job. They exist to have records on file so that the inventor can point to a specific place and time and say, "See, I invented it before you?" and therefore have the manufacturing and sales rights for a given amount of time! That's all! That's it."

"In my opinion, the U.S. Patent Office way oversteps their function by discrimination of many patents. But then, their attitude has been strange for a

long time. Charles H. Duell, director of the U. S. Patent Office in 1889 states, '...everything that can be invented... has been invented.' I always get a chuckle when I think of that."

"In reality, in our so called 'free enterprise' system, the marketplace will determine the value of a patent. A patent that doesn't work or is impractical when applied as a device simply won't sell. A device that is superior has a chance to take over from the existing technologies. How many people really care what happens when they flick on the light switch? Most people simply want the light to come on! And if they can get the same light for a fraction of the cost, then they would care about the saving without worrying about the 'new' technology that made it possible. Practical devices will sell, and it shouldn't be up to the patent office to determine the practicality of a device."

"You can believe it or not, but we live in a police state. The United States and Canada have only the illusion of 'freedom'. I'd very much like you (or anyone) to prove this statement wrong for two reasons. First, I really want to be free and have the rights granted me by the original Constitution. Second, if you look into the subject hard enough to prove me wrong, you'll find that I'm right and you'll be educated, which is my intention. I still retain the hope that we can, if enough people get together, turn our countries back into the dream held by our ancestors."

Incidentally, suppression occurs in other countries as well. Johan Grander of Austria developed a revolutionary magnetic motor, but was turned down by the Austrian patent office with the excuse: "inventions which are detrimental to products in existence may not be granted a patent." There are at least 20 cold fusion patents on hold here in the U.S. another form of passive suppression.

(Also from: The Coming Energy Revolution by Jeans Manning)

### **Some Reasons For Over-Unity Suppression**

1. The strong oil lobby has throughout recent history suppressed high mileage carburetors through violent threats or rigid mandates. Their tremendous investments in oil fields, refineries and distribution systems wields a big stick against free energy, over-unity systems. (They have to be informed, and it will take tens of years to implement this technology.) They can be a major player in this revolution.

2. Some have said the world is on the "brink of financial collapse." And work of revolutionary breakthroughs in the energy production or distribution system could cause economic upheavals in our economic system which is based on finite sources of money and energy. The powers that be can control the masses by controlling the energy supply. They don't want to lose that control

3. As Einstein stated, "Great ideas often receive violent opposition from mediocre minds." Egos of competing companies, or establishment views that this technology is a hoax or preposterous can also create these violent oppositions.

4. The unenviable tasks of adding to or changing some of the laws of classical physics and chemistry will take vast amounts of research time before verification of these new discoveries can be made by the ivory-tower university types.

5. People in power (academic, political, technological, or business) do not like revolutionary changes which might threaten their position or standing.

6. Ignorance and indifference by the masses in this materialistic uninformed age about the state of the earth's delicate ecosystem and the effects of pollutants on human, plant and animal life.

7. National Security: This technology used in a war would be a decided advantage. The major cold war is over. Let's help financial independence of the masses and save Mother Earth.

8. Galactic Security: Over-unity magnetic technology is related to anti-gravity, space, time warping (unified field theory), and Area 51 Top Secret technology. The Galactic Cold War has begun.

In summary, I am writing this article for three main reasons.

1. To inform the public that this new energy revolution is for real, or why would the competing establishment corporations OPEC, etc., and government agencies be carrying on such suppressive endeavors? Write your legislators and inform them as to what is going on. Tell them we need this new revolutionary technology to be developed worldwide, including in the U. S., to restore Mother Earth, whose once pristine environment is in a world of hurt at present. Is it almost a foregone conclusion that the extreme weather events we are experiencing are a result of mankind's careless exploitation of the earth's resources.

2. To inform the inventors not to make sensational claims on their local TV stations or newspapers about recent breakthrough. Keep it quiet if you want yourselves or your technology to survive! Don't antagonize the oil or nuclear cartels by making statements that this technology will put them out of business. It is going to take a long time to get the technology to the mainstream and replace oil imports or nuclear power: By that time these technologies can be an economic part of the multinational oil and nuclear corporations.

3. To raise one question as to why the SWAT teams, or the men in black, are so brash in their operations of suppression? With no warning or explanation to the inventors, they act. These actions seem irrational in a country that was founded on freedom of expression. It seems prudent for the level of government controlling these black helicopters' and SWAT teams to give



warning and reasons for their actions before they act. Please raise this question with your congressman.

Some have said that black helicopters are part of the Bureau of Alcohol, Firearms, and Tobacco which operates under the US Treasury Department, which in turn operates with the Federal Reserve, which is a private corporation, which operates with the World Bank, over which the US government apparently has no jurisdiction. Thus, they can do what they damn well please. At this time. Mr. President, Congressmen, and US Department of Justice.

Take Note! A movie released this summer (August 2, 1996), Chain Reaction, has the theme of active suppression! REAL ACTIVE!!!

Andrew Davis, director of The Fugitive, is producing this action-packed thriller movie Chain Reaction, in which visionary research scientists have discovered the key to cheap, pollution-free energy. When the team's leader is assassinated, and the laboratory is destroyed in a cataclysmic explosion, the machinist and two fellow physicists are framed for the murder. With the help of the lab's investor, the framed group goes on the run with half a dozen federal agencies pursuing them across country. They find themselves trapped in an underworld of technological espionage where neither they, nor their discovery, are meant to survive. Three time Academy Award nominee, Morgan Freeman, plays Shannon, the mysterious head of a foundation that is backing the energy research project. This will be a big-time movie with executive producer Richard Zanuck, who has produced Academy Award pictures -- Driving Miss Daisy, The Sting, and Jaws. Don't miss this blockbuster!

The Cold war is over, but the cold war on the lowly but enlightened inventor is still on by the Fascist corporations who want complete control of the world's energy distribution system, regardless of the effect on the masses' health, particularly on the large cities worldwide, or the effect on Mother Earth and its delicate water-air-envelope.

Work continues on this technology and at a faster pace than in the past. Many inventors have left this country to work in other countries where a more futuristic environment exists, and where there is less government and corporate fascism. Most of the inventions I have mentioned there in his article have gone underground, waiting for the time and place where this technology will be a necessity for a free market, modern, environmentally sensitive society.

## **Appendix 1**

Marion(Mike) Menning  
Senator 26 th District

Engerman, Minnesota 56126

and  
Room 2K State Capitol \_\_\_SENATE\_\_\_  
St. Paul Minnesota 55155 State of Minnesota  
(612) 296-4171

July 2, 1979

Senator Dave Durenberger  
353 Russell Senate Office Bldg.  
Washington, DC 20510

Dear Senator Durenberger:

Several months ago, a new type of machine was developed by Mr Johnson of Magnatron, Inc. At Elgin, Illinois, to see the engine and they know the engine works. It is not just some wild idea that somebody has.

The reason I am writing you a letter is that a restraining order has been placed on Mr. Johnson, the Chairman of Magnatron, Inc. Prohibiting him from producing the engine. I have been trying to find out the reason why. Mr. Johnson does not know why either. Would you please send a letter or make a telephone call to the Illinois Attorney General's office and ask what's going on and why they are trying to stop prosscution of this engine? The attorney general's phone number is (313) 793-3444. Mr Overhand is in charge of the case. I would appreciate your cooperation in this matter.

Sincerely

Marion Manning  
State Senator

enc.  
Pk

## **Appendix 2 - Keeping Inventors Quiet**

Adam Trombly knows about the Secrecy Act, In the early 1980's Trombly and another young scientist, Joseph Kahn, Ph.D., naively believed that the "experts" would welcome their space-energy invention. (See part II. for more information on space energy.) However, hen Trombly and Kahn applied for a patent, the United States Patent Office notified the Department of Defense. Instead of congratulations, Trombly and Kahn received a secrecy order. They were ordered not to talk about their invention to anybody, not to write about it, and even to stop working on it. They certainly couldn't tell the media.

If you were an inventor trying to patent an important new-energy discovery. You might receive a secrecy order along the lines of the one reproduced here. According to information obtained under the Freedom of Information act by the Federation of American Scientists, the Pentagon placed

774 patent applications under secrecy orders in 1991 -- up from 290 in 1979 -- and 506 of these orders were imposed on inventions by private companies. The government has standing gag orders on several thousand inventions. The following order, issued in the 1980's, was obtained by inventor ken MacNeil of Georgia and revealed in 1983.

SECRECY ORDER

(Title 35, United States Code [1952], sections 181-188)

NOTICE: To the applicant above named, his heirs, and any and all his assignees, attorneys and agents, hereinafter designated principals.

You are hereby notified that your application as above identified has been found to contain subject matter, the unauthorized disclosure of which might be detrimental to the national security and you are ordered in nowise to publish or disclose the invention or any material information with respect thereto, including hitherto unpublished details of the subject matter of said application, in any way to any person not cognizant of the invention prior to the date of the order, including any employee of the principals, but to keep the same secret except by written consent first obtained of the Commissioner of Patents, under the penalties of 35 U.S.C. [1952] 182, 186.

Any other application already filed or hereafter filed which contains any significant part of the subject matter of the above identified application falls within the scope of this order. If such other application does not stand under a secrecy order, it and the common subject matter should be brought to the attention of the Security Group, Licensing and Review, Patent Office.

If, prior to the issuance of the secrecy order, any significant part of the subject matter has been revealed to any person, the principals shall promptly inform such person of the secrecy order and the penalties of improper disclosure. However, if such part of the subject matter was disclosed to any person in a foreign country or foreign national in the U.S., the principals shall not inform such person of the secrecy order, but instead shall promptly furnish to the Commissioner of Patents the following information to the extent not already furnished: date of disclosure, name and address of the disclose, identification of such part: and any authorization by a U.S. Government agency to export such part. If the subject matter is included many foreign patent application for patent this should be identified. The principals shall comply with any related instructions to the Commissioner.

This order shall not be construed in any way to mean that the government has adopted or contemplates adoption of the alleged invention disclosed in this application, nor is it any indication of the value of the invention.

At the conference where he revealed the secrecy order, Macneill advised inventors of new-energy devices to go public? "Get the information or the device out there to enough people that they could not stop you."

\* "Keeping Inventors Quiet" and "Secrecy Order" courtesy of the Corning Energy Revolution by Jeane Manning, Avery Publishing Group, P. 163-4



## ADVANCED ENERGY PROTOTYPE TESTING AND PREPARATION FOR COMMERCIALIZATION

BY MIKE FISHER

---

In the "free energy" field, testing and obtaining reliable results has often frustrated inventors and investors alike. Almost every month over-unity results are published in one journal or another. We all want to hear the good news, but unfortunately of the dozens of claimed over-unity technologies our group has not yet witnessed one device that we can be completely sure of, although we are confident that they exist, and will in due course prove to be viable over-unity technologies.

So what's the key to attracting serious investment capital for a 'free energy' machine? **Good test results.** As an investor in several technologies, and I believe other investors would agree with me, that a prototype which has thoroughly documented and independently performed (by multiple, quality engineers) test results can easily make a device worth ten or even hundred times more to a potential investor. And in the end, the true test which is sure to attract the proper attention is IF the device can run itself – a test which few devices pass, even though they claim over-unity.

The following is a brief summary of our group's experience with a variety of researchers and is aimed at helping inventors and researchers test their machines in order to attract the investment they deserve for the successful commercialization of their technology.

### I. Overall Strategy

An investor in technologies in this new energy field needs to feel comfortable on the following four main technical points:

1. The prototype is over-unity or will, with development, achieve over-unity. Ideally it will be self sustaining (can run on its own generated power), stable, reliable and producing useful power.
2. There are no hidden batteries, collectors, antennas etc. which convert energy from other known (or unknown) sources.
3. The prototype can be duplicated, scaled up or down and can be built inexpensively to produce real products.
4. The prototype has been independently tested by a credible organization.

## II. Experimental Technique

The following experimental techniques highlight some possible pitfalls in the commercialization process if they are not observed.

**Independence of input and output** - it is most important that the input and output signals are truly independent. Great care needs to be taken to ensure isolation, especially when measuring very small electrical power signals. One particular error we encountered in an electrical "converter" was a situation where the common earth connection for the instrumentation was also connected to the negative terminal of the input and the negative terminal of the output. In this configuration the earth itself carried a current showing an apparent over-unity result. However, when fully isolated the efficiency was below 100%.

**Accuracy estimation** - As an important discipline, experimenters may find it useful to carry out an estimation of accuracy for all elements of the test setup, experimental technique and instrumentation. Sometimes an experimenter will have excellent instrumentation but the experimental technique may be subject of error, and in several cases we have come across some huge errors based on false assumptions. One of the most glaring errors I have personally encountered has been in the measurement of shaft power into a supposed over-unity homopolar generator. The generator was driven by an electric drive motor through a belt drive, and the shaft power at the generator was estimated from the electric power delivered to the drive motor at open circuit and also at full load. Incremental efficiency was calculated from these two conditions and an over-unity incremental efficiency was used to justify the potential of a machine capable of absolute over-unity. However at low loads the power factor of a drive motor was nearly 90° (and thus the efficiency of the drive motor was only about 10%) and researcher had erroneously assumed in his calculations that the drive motor efficiency was about 70% thus leading to a gross error in the estimation of shaft power delivered to the generator. The nameplate efficiencies of drive motors and the performance curves supplied by manufacturers need to be checked and should only be used with caution. In the above circumstance a simple dynamometer could have solved the problem very inexpensively.

**Have a double check on every instrument** - It is wise to have a backup method for every measurement taken. It is easy to make a slip up in technique or make incorrect assumptions, however these are easily picked up by a second set of readings or a double check. This may take the form of a simple calibration of a gauge, meter or dynamometer, or may go as far as a complete set of backup instrumentation, which in most cases is unnecessary when only a proof of concept is required. In the case cited above shaft power at the input of the generator was eventually measured using an in line torque meter and optical revolution counter and was double checked for ball park accuracy

using the electrical power input to the motor when under load when the motor characteristics are more accurately determined. The output of the generator was measured at several points electrically and if it had showed promise we would also have double checked the electrical readings using a calorimetric technique.

**Beware of signal transients and duty cycle** - Many experiments rely on pulsing an input signal for a small percentage of the time and generating an output, e.g. the switched reluctance motors and some resonant devices. The exact wave form of inputs and outputs need to be measured using an oscilloscope, and in our testing we have experienced many errors both in instrumentation and also in the calculation and interpretation of results. Standard meters measuring RMS voltages and currents are only accurate with AC sine waves, and power factor must be taken into account.

**Calorimetry and cold fusion** - I have not personally tested any cold fusion devices and do not claim to be an expert in calorimetry, but I would like to make one point here about calorimetry. Calorimetry can be highly complex and relies on the meticulous skill of the experimenter. If an outside party wants to discredit a technology that used calorimetry to test it, they will start at the experimental technique. Likewise, an investor needs to feel comfortable that the calorimetry is really accurate before parting with hard earned dollars. I understand several cold fusion experiments have come under attack particularly in regard to the calorimetry, the original Pons and Fleischmann experiments being well publicized.

**Industry Standards** - In relation to the testing of motors and generators there are industry standards e.g. NEMA and UL in the USA. Some experimenters are not familiar with these standards and have come adrift by measuring the incorrect parameters. For any regular motor and generator full performance figures of power, torque, efficiency etc. against speed are published by the manufacturer and are most illuminating for an experimenter not familiar with testing or detailed analysis. When our group tested one motor that was claimed to be over-unity, we discovered it was only about 10% efficient, and it was later revealed that the experimenter had measured the **voltage output at open** circuit and the **current delivered at closed** circuit and multiplied the two together to obtain a power output. It might appear obvious, but voltage and current must be measured at the same time.

### III. Third Party Validation

The first step for a researcher is to prove to himself that he is confident with his results. The second step is to have an independent engineer test the device to raise the level of confidence. There are many people in the field who have considerable experience in testing and have no interest in suppressing

these technologies. The following have offered their services for testing potential over unity machines:

- ◆ Dr Gene Mallove, the Editor of Infinite Energy (603-228-4516), has recently set up a testing facility in New Hampshire, and has been a champion for cold fusion for many years.
- ◆ Bob Emmerich in Fort Collins, Colorado (970-482-3731) through the ANE (Academy for New Energy) is a very experienced test engineer who has worked for Hewlett-Packard for over 20 years.
- ◆ Walter Rosenthal in Santa Maria, California (805-934-2058) has over 40 years experience in instrumentation and testing with aerospace companies and has been testing machines in this field for about 7 years. Walter has over \$30,000 worth of state of the art electronic measuring equipment for measuring just about any signal.

These experts among others can give a level of confidence and credibility necessary to move forward commercially. As a prudent commercial formality it is recommended that the researcher should enter into a non-disclosure agreement with the test engineer prior to testing. The above three people mentioned are all of high integrity, but it is always best to protect all parties by not revealing proprietary information and trade secrets unless absolutely necessary. You don't have to disclose how the device works, just what the results are (i.e. input power versus output power).

#### **IV. Certification**

A note about the commercial process may be useful for researchers. Some investors may be comfortable proceeding solely on a researcher's own test results. Most require a professionally qualified engineer to test the machine. To obtain the maximum commercial leverage the technology must be packaged properly with regards to patents, ownership of rights, confidentiality and the subject of this article, testing. An independent test report is likely to be required. Someone who has worked in this field may not be regarded as fully independent no matter how excellent his credentials or technical expertise. Therefore it is important to make the distinction between (a) testing the machine for one's own satisfaction and (b) the more extensive certification as part of a "marketing package" to take to more sophisticated investors and senior contacts.

A test report suitable for investors and certified by one or more credible engineering establishments or universities should contain for following elements:

- Definitive statements about what the technology is and what it is not, particularly in respect of where the excess energy is coming from.



- Testing carried out in accordance with specified industry standards (if applicable).
- A clear description of the experimental setup, techniques, instrumentation, readings taken, accuracy, how the results were calculated and conclusions.
- A statement that the device is not, for instance, a battery, solar collector, transformer, a thermal collector, or a radio receiver etc. In other words a statement is needed to definitively eliminate the common sources of energy.
- An opinion about how the technology could be duplicated, scaled up or scaled down, and suitability for varying applications.

## GOVERNMENT INVOLVEMENT IN SUPPRESSED INVENTIONS

BY PEA RESEARCH

---

*DATE of INCIDENT*

*DESCRIPTION of INCIDENT*

Unable to Date:

CARBURETION, MOORE - The most productive in the field of carburetion was George Arlington Moore. Out of 17000 Patents, 250 of them were related to carburetion. As far back as the mid 1920's, Moore was capable of virtually eliminating carbon monoxide pollution with his carburetors. People in the automotive field considered Moore to be a genius and couldn't understand why the automobile industry ignored his inventions.

1925

GENERATOR, FREE ENERGY, HENDERSHOT - Lester Hendershot successfully builds and test a FREE ENERGY device. (see 1961)

1930's

GENERATOR, FREE ENERGY, MORAY - Henry T. Moray is refused a Patent on his cold semiconductor cathode because the patent examiner couldn't understand how it could emit electrons. 20 years later the development of the transistor proved that his device could actually have worked! (see 1940)

Jan. 3, 1935

CARBURETION, POGUE, Pat.#353538 (Canadian) - Charles N. Pogue is issued a Canadian Patent for a High Mileage Carburetor. (see 1/7/36)

Apr. 9, 1935

CARBURETION, POGUE, Pat.#1997497 - Charles N. Pogue is issued a Patent for a High Mileage Carburetor. (see 1/7/36)

Jan. 7, 1936

CARBURETION, POGUE, Pat.#2026798 - Charles N. Pogue is issued a Patent for his newer High Mileage Carburetor. Pogue used the carburetor for about ten years on his car and produced about 200 carburetors thru the Economy Carburetor Co. (see 4/30/36; 8/10/36)

early 1936

CARBURETION, POGUE - BREEN MOTOR CO., Winnipeg, Manitoba, Canada: Tests the POGUE Carburetor on a Ford V-8 Coupe and got 26.2 miles on one pint of gasoline. The performance of the car was 100% in every way. Under 10 mph the operation much smoother than a standard carburetor. T.G. Green, President of the BREEN MOTOR CO., did the tests. (see 1/7/36)

Apr. 30,1936

CARBURETION, FORD MOTOR CO. - FORD MOTOR CO., Winnipeg, Manitoba, Canada: Tests the POGUE Carburetor and is at "a loss to understand" how the carburetor got "25.7 miles on one pint of gasoline"! (That's approximately 205 mpg). Mr. W.J. Holmes and Mr. Purdy conducted the test for FORD MOTOR CO. (see 1/7/36)

Aug. 10,1936

CARBURETION, POGUE - S. Stockhammer tested the POGUE Carburetor on a 1934 Ford V-8 Coupe and got 28 miles per pint of gas. "I can say the performance was all anyone could desire in every shape of form." (see 1/7/36)

Dec. 12, 1936

CARBURETION, POGUE - Canadian Automotive Magazine states that the standard carburetor gets about 25 mpg at only 9% efficiency. Therefore the POGUE carburetor is 72% efficient overall at 200 mpg. (see 1/7/36)

1940

GENERATOR, FREE ENERGY, MORAY - Henry T. Moray demonstrates before members of the Public Utilities Commission (PUC) his FREE ENERGY generator that gave a continuous output of 250,000 volts with no apparent input. The next day he was found shot in his lab and all of his notes and device were stolen. Currently, the Cosray Research Inst. of Salt Lake City

has been collecting Moray's papers from old acquaintances and attempting to duplicate the device. (see 1930's)

Oct. 22, 1940

CARBURETION, NEWBERY, Pat.#2218922 - Ivor B. Newbery gets a Patent for a high mileage carburetor that he says delivers a truly dry vapor to the engine and produces very little, if any, exhaust pollutions.

1945

Carburetors marked "POGUE CARBURETOR, DO NOT OPEN" were used on unnamed source American Army tanks throughout WWII but were removed from circulation after the war ended. (see 1/7/36)

1946

GENERATOR, FREE ENERGY, COLER, von UNRUH - CLASSIFIED BRITISH INTELLIGENC REPORT: A German researcher by the name of Hans Coler, was visited and interrogated about his "Magneto-tromapparat" FREE ENERGY generator. The inventor claimed to get electrical energy without the use of a chemical or mechanical source of power. This device consisted of only permanent magnets, copper coils, and condensers in a static arrangement and delivered 450 mv for a period of some hours. Coler also claimed his "Stromerzouger" could deliver 6 kw of power from the few watts delivered by a dry cell. (see also, Joseph Newman).

1947

FLYING SAUCER, T. BROWN - Townsend Brown constructed Flying condensers shaped like Saucers. A high positive charge on the leading edge caused thrust to be generated in the direction of the region of low flux density. His Saucers required no jets or propellers, no moving parts at all. They modified the gravity field around themselves to produce, in effect, the incline of a "hill" under the craft, which they slid down like a surfboard on a wave.

late 1950's

CARBURETION, FISH/KENDIG - Variable Venturi - The Fish/Kendig Variable Venturi carburetors get some very interesting mileage figures. The Fish carburetor even got into production on a small scale, but for some unknown reason, these carburetors fade away in the early 1960's. (see early 1970's)

1953

CARBURETION, POGUE - CARS Magazine states that in the opening months of 1936, Pogue panicked the Toronto stock exchange and threw fright into the major oil companies. Stock exchange offices & brokers were swamped with orders to dump all oil stock immediately. This same article states that Winnipeg's largest automobile dealers tested the POGUE carburetor and got results of up to 216.8 mpg! (see 1/7/36)

Mid 1950's

CARBURETION, BASCLE, Pat.# ? - Joseph Bascle get a Patent for an improved carburetor which was used on every car in the Yellow Cab fleet in Baton Rouge, NY. It raised mileage by 25% and decreased pollution by 45%.

1953

INTEGRATRON, VAN TASSEL - UFO Contactee, George W. Van Tassel begins the construction project on the INTEGRATON machine in Yucca Valley, CA. Its' purpose is to rejuvenate the human physical frame.

Aug. 23, 1958

FLYING SAUCER, OTC-X1, CARR - Spacecraft Convention, Pleasonton, CA: Panel discussion between Daniel W. Fry and the inventor of the OTC-X1 Flying Saucer, Otis T. Carr and Major Wayne S. Aho, formerly Army Combat Intelligence Officer during WWII. (see 5/5/60)

Mar. 9, 1959

FLYING SAUCER, OTC-X1, CARR - Immediate News Release to ALL Media: OTC Enterprises announces plans to market kit plans to build a prototype model of the firm's projected spacecraft, the OTC-X1, said to be under construction now for launching later this year. Mr. Carr plans to launch a six-foot operating model in April in Oklahoma where it is now being built in field laboratories. (see 4/19/59;5/5/60)

Apr. 19,1959

FLYING SAUCER, OTC-X1, CARR - The OTC-X1 didn't fly for several reason today: Mr. Carr was in the hospital for eight days with lung hemorrhage. There is no indications of cancer, TB or other lung ailments.

Also, in the preliminary pre-flight test the accumulator developed a leak which sprayed mercury all over the inside mechanism. "We don't plan to announce the next pre-flight test in advance", said Mr. Wayne S. Aho. (see 5/5/60)

Nov. 10, 1959

FLYING SAUCER, OTC-X1, CARR - Otis T. Carr gets a Patent for an "amusement device" (Flying Saucer). He claims that this actually demonstrates a workable space craft. Pat.#2912244

Dec. 10, 1959

FLYING SAUCER, OTC-X1, CARR - Mr. Wayne Aho hopes to say, "take me to your leader, moon-man!" Mr. Aho announces plans to take the OTC-X1 to the moon at 12:01 a.m. on Dec. 7, 1959. He will get there in 5 hours and orbit it for 7 days, then he will return to earth. The Carr space ship is 45 ft. in diam. and weighs 30 tons and is powered by electricity. Maj. Aho was formerly an Army Intelligence Officer who says he landed on Omaha Beach in Europe on D-Day and won the Bronze Star and Purple Heart for wounds received in the Battle of the Bulge. He claims to have seen 13 Flying Saucers in flight. (see 5/5/60)

May 5, 1960

FLYING SAUCER, OTC-X1, CARR Pat.#2912244 - Victorville, CA: First time ever in any newspaper: Otis Carr tells how his Flying Saucer, the OTC-X1, works. Carr developed his power plant for the saucer at the Osbrink Plant in Apple Valley. The OTC-X1 is described "as being two tops that spin in opposite directions around a single axis...The entire circular-foil craft that is Mr. Carr's most profound development, is an assembly of only two major moving mechanical parts." (see 3/9/59;1/61)

June 2, 1960

FLYING SAUCER, OTC-X1, CARR - Otis T. Carr told an "open house" audience of 300 people on Memorial Day that it is a "treacherous misstatement of fact to say or infer that we (OTC Enterprises) are coming to California to raise money in stock sales". Carr appeared to be planning to sell rights to build, sell or operate the OTC-X1 Flying Saucer he claims he'll be producing at the former Osbrink Plant. Thus Carr would't be violating a federal injunction secured by the U.S. Securities Exchange Commission ordering him to stop selling unregistered stock. (see 5/5/60)

Jan., 1961

FLYING SAUCER, OTC-X1, CARR - True Magazine labels Mr. Otis Carr and his OTC-X1 a hoax and a con-artist. Attorney General J. Lefkowitz is investigating him and Lefkowitz said that Mr. Carr has bilked \$50000 from various people in New York. (see 5/5/60)

1961

GENERATOR, FREE ENERGY, HENDERSHOT - Dr. Ed Skilling, from Columbia University, successfully builds and test a HENDERSHOT free energy device, out of which he got 300 watts. Skilling had been associated with Hendershot and learned of the device thru him. The generator was self-resonant at 500 khz. (see 1925)

May 2, 1961

CARBURETION, SHELTON, Pat.#2982528 - Robert S. Shelton gets a Patent for a high mileage carburetor that he claims gives 8 to 10 times the mileage of a standard carburetor.

July 20,1961

GENERATOR, FREE ENERGY, COLTON - IMMEDIATE PRESS RELEASE: I, Norman Evans Colton, do hereby declare under oath that I have perfected a machine to draw electricity from the atmosphere without the use of any fuel. The machine is operated entirely by environmental gravitic forces. A newly constructed "Colton-Gravity-Electric-Engine" has been installed at the Claremont Hotel in Berkeley, CA, where it may be seen, examined, evaluated and photographed.

1963

BINDING METER, W.B. SMITH - Wilbert B. Smith, founder and editor of "Topside" magazine, claims to have had contact with Aliens and to have found out the reason why there space ships have crashed. There are certain areas of this planet that are afflicted with "reduced binding". The 3 basic fields of nature that affect "binding" are tempic, electric and magnetic, all of which are non-linear in there reactions to each other. He claims to have developed a "binding meter" to measure these forces.

Dec. 26, 1966

CARBURETION, SCHWARTZ, Pat.#3294381 - Harold Schwartz gets a Patent for a high mileage Vaporizer Carburetor that he claims to be 100% efficient with virtually no exhaust pollutions.

1968

CARBURETION, FORD MOTOR CO. - FORD MOTOR CO. begins experiments with an engine that has a new kind of combustion chamber. A 430 cub. inch is tested and runs very well on a 26:1 air/gas mixture. Estimate possible production by 1985. (see 1985)

Early 1970's

CARBURETION, KENDIG - A young college student (name unknown), entered his Mercury "gas hog" in the California Air Pollution car race and won hands down. He was using the KENDIG Variable Venturi carburetor that a small company (name unknown), manufactured in Los Angeles for racing cars. Within a week the student was told to remove the carburetor since it wasn't approved by the Air Resources Board (ARB). His car had reduced pollution and doubled the gas mileage (for that model). (see late 1950's)

1970's

ALCOHOL - The U.S. Army's Nalick Laboratories in Massachusetts discovered and developed certain fungi which could convert a wide variety of cellulose into the sugars necessary for producing alcohol. Using the fungi to reduce paper scrap, they could produce 65 gals. of high grade alcohol from one ton of scrap.

1972

OTEC, NASA - NASA Report on OTEC (Ocean Thermal Energy Conversion): "Tapping the energy of the Gulf Stream could supply all the electrical energy needs of the US as far ahead as 1985 with only three-tenths of a degree reduction in the temperature of the great warm ocean river. This reduction may be beneficial as it would slightly offset the ocean's thermal pollution due to other uses."

Apr. 4, 1972

CARBURETION, TUCKER, Pat.#3653643 - Oliver M. Tucker gets a Patent for a high mileage Vaporizer Carburetion System. This is the basic type that La Pan used as mentioned in Mechanics Illustrated. (see 1974)



1973

CARBURETION, SHELL OIL CO. - At the Annual SHELL OIL Companies employees contest, a highly modified 1959 Opel sets the record with 376.59 mpg at Wood River, IL.

1974

CARBURETION, DRESSERATOR - Dresser Company SELLS OUT to Holley Carburetor and FORD MOTOR CO. Lester Berriman spent 5 years designing and testing the "Dresserator" carburetor for Dresser Co. which used a super-accurate mixture control to obtain a 22:1 mixture. Pollution standards were passed along with a typical gain of 18% mpg.

May, 1974

GAS/WATER ADDITIVE - John Andrews, a Portugese chemist, demonstrated a water to gas additive before Navy officials which allowed ordinary water to be added to gasoline without decreasing the combustability of the gas and would drive the cost of gasoline down to 2 cents per gallon. When Navy officials finally went to his lab to negotiate for the formula, they found Andrews missing and his lab ransacked.

Mid 1970's

CARBURETION, FRANCH, KRAFT - Guido F. Franch demonstrates a water-to-gas miracle to the chemists at HAVOLINE Chemical Co., MI, and to the University of Michigan. Using a "green powder" starting agent derived from soaking coal in a liquid (unnamed), he cold make water operate a car better than gasoline. He said he learned this process from a coal miner named Alexander Kraft over 50 years befor.

1974

CARBURETION, La Pan - An article from Mechanix Illustrated about "Humidifier type fuel systems" tells of a man by the name of La Pan who claims to get from 60 to 100 mpg with his system. Mechanics Illust.

July, 1974

GENERATOR, FREE ENERGY, EVGRAY Pat.#3890548 - The L.A. District Attorney, acting under orders from the "Top", raids Ed Gray's assembly plant and condiscated his prototype generator as well as his plans and records, brought numerous false charges against him, and defied all attempts

by Gray's lawyers to get the confiscated materials returned. Gray's opponents have driven him into bankruptcy. (see 6/17/75)

Apr. 22, 1975

GENERATOR, FREE ENERGY, ECKLIN, Pat.#3879622 - John W. Ecklin, of Alexandria, VA, gets a patent for a FREE ENERGY generator that is powered by 2 kw and delivers 12 kw output.

June 17, 1975

ENGINE, FREE ENERGY, EDWIN GRAY, Pat.#3890548 - Edwin V. Gray, of Evgray Enterprises, Van Nuys, CA, gets a Patent for a FREE ENERGY automobile engine. The engine starts off of two car batteries and once it gets going, it recharges the batteries and powers the car. Unfortunately, Evgray Ent. has become embroiled in a controversy with the Securities Exchange Commission (SEC), which is unrelated to the engine itself but has halted the development of the engine. (see 1975)

1975

ENGINE, FREE ENERGY - Governor Ronald Reagan, of California, gave a special commendation to Edwin Gray, of Van Nuys, CA, for his Patent of a FREE ENERGY automobile engine. (see 6/17/75)

Aug. 12, 1975

GENERATOR, FREE ENERGY, KINNISON, Pat.#3899703 - Robert W. Kinnison of Fort Collins, CO, gets a Patent for a FREE ENERGY generator which offers a hope for a fuel economy. His design resembles ECKLIN'S generator. (see 4/22/75)

Sep. 18, 1975

Joseph C. Yater invents an Heat-to-Electricity convertor that he says will cost the consumer approx. \$200 and would be up to 90% efficient. The device operates by capturing "fluctuation voltage" (static noise heard on radios and amplifiers). The rooftop device would be heated by the sun and use millions of microcircuits to tap the freed electrons from heated molecules. Yater took his device to the Government, which declared that his device had "real potential". After being promised a working model within 6 months by the

Gov't., they came back to him with the reply that the device would be impractical.

1976

CARBURETION - A modified Ford Pinto equipped with a turbocharged Nissan diesel engine is tested and gets up to 80 mpg.

1977

CARBURETION - Tom Ogle of El Paso, TX, claims to have gotten 100 mpg on a 1970 Ford Galaxie with a V-8 engine. The Ford used only 2 gals. of gas on a trip from El Paso, TX, to Demming, NM, roundtrip! His Vapor Fuel System eliminates the carburetor and has no exhaust pollution emission!

July 26, 1977

WEATHER CONTROL, CONSTABLE - Trevor James Constable aims his Weather Control Machine at the cloud system near Palm Springs, CA, and created a coastal cooling during an excessive heat spell. He also produced record rains for Utah in the worst drought stricken area of the United States. He successfully completed other Weather Divergence plans and notified the Federal Government of these plans as required by Federal Regulations.

Apr. 2, 1978

ELF WAVES - A man-made standing columnar ELF wave collapsed at Bell Island, Newfoundland, Canada, today. This conclusion was reached after an analysis done by the Dept. of Geology at Memorial University of Newfoundland and with senior officials of Newfoundland and Labrador Hydro. Affects of this wave collapse were: Power lines were vaporized. A power surge was reported. A voltage regulator was fused. All fuses leading to the local power company's transformer melted, yet the transformer escaped unscathed. Ball lightning was seen, rumbling and humming below 60 hz was felt and heard.

1978

CARBURETION - The Flex Gas Vaporizer (as advertised in national magazines) and sells for a reasonable price, claims to double gas mileage on most any car and gets 110 mpg on some!

Sept. 3, 1978

SCRAMBLER DEVICE, Patent applied for but REFUSED. - U.S. Government Agency Restricts CB Radio & Telephone Privacy device: Four inventors, Carl Kicolai, William Raike, Carl Quale and David Miller of Seattle, WA, developed a device to prevent eavesdropping on CB radio and telephone transmissions for nonmilitary, nongovernment use. The NSA was quick to issue a secrecy order against them. This means they may not talk about the invention in any detail without risking a jail term! The order was received six months after a patent was filed for the device. "Your application...has been found to contain subject matter, the unauthorized disclosure of which might be detrimental to national security," wrote the Patent Office. (This appears to be part of a general plan to limit the privacy of the American people.)

1979

CARBURETION - Ralph Moody, Jr., of Oak Hill, FL, gets 84 mpg from his modified Ford Capri which has been equipped with a turbocharged 4 cylinder Perkins diesel engine.

Apr. 24, 1979

MOTOR, FREE ENERGY, JOHNSON, Pat.#4151431 - Howard R. Johnson gets a Patent for a FREE ENERGY motor that starts itself and would deliver 5 kw from permanent magnets. (see Spring, 1980)

Spring, 1980

MOTOR, FREE ENERGY, JOHNSON - Science and Mechanics magazine interview regarding the JOHNSON FREE ENERGY motor: When asked if he (Johnson) thought that the load on his motor might drain the magnetic spin (of the electrons) he replied, "I didn't start the electron spins and I don't know anyway to stop them - do you?" The Johnson Permanent Motor is one of the most promising possibilities in the world of "Free Energy". It is simple to construct and yields high output. (see 4/24/79)

Sep. 11, 1980

RADIONICS - CHARLES WHITEHOUSE - Norfolk, VA: Lawyer Charles E. Poston decided he had the "right" to "judge" Dr. Charles Whitehouse, of Virginia Beach, VA and revoke his chiropractic license on the grounds he

was practising medicine outside the scope of his chiropractic profession. Guilty?... He was helping many people FREE OF CHARGE, and especially helping mentally retarded children with color therapy and radionics. Whitehouse is on the Board of Directors of the U.S. Psychotronics Assoc. and is an expert Radionics Operator. Even the U.S. Navy has purchased one of his radionics inventions for tracking submarines. Whitehouse was giving away approx. \$200,000 in treatments a year. (see 12/80) (see 1/7/81)

1980

CARBURETION, POGUE - Mr. Arthur C. Sgrignoli, after 45 yrs., has built a legendary POGUE carburetor by hand and is said to have achieved an efficiency of 86%. Contact was made thru his brother, William J. Sgrignoli. (see 1/7/36)

Dec., 1980

RADIONICS - Norfolk Circuit Court, VA: Dr. Whitehouse won his appeal and was awarded his chiropractic license back. (see 9/11/80)

Jan. 7, 1981

RADIONICS - Virginia State Supreme Court, VA: The lower courts' decision is reversed and Dr. Charles Whitehouses' chiropractic license is again revoked. Whitehouse will again be going to court in March, 1981. (see 1/7/81) (see 12/80)

Jan. , 1981

POGUE, Charles N. - As of January, Charles N. Pogue is still dive at age 81 and is living in a rest home in Winnipeg, Canada. He refuses to talk to anyone or to receive visitors from outside his own family. (see 1/7/36)

1981

TESLA EXPERIMENTER, ROBERT GOLKA - Wendover, UT: Robert Golka, a well-know Tesla researcher, has been victimized by an attack on his workshop which has, for years, been in a deactivated Air Force hanger. His high powered energy tower outside the hanger has been partially destroyed. A witness said insulators and sections of the tower were laying around the base. In the mean time the rent on the Air Force hanger has been raised 1000 percent! These new difficulties now threaten to bring an end to his research with Tesla devices.

1981

SUPER PAINT - Research funded by Naval Air Systems Command has come up with a polished film paint that will reflect 98% of the energy directed at it by a high energy laser beam weapon thus making Star Wars obsolete. [So why haven't we channeled the money to more worth while causes?]

1981

CANCER CURE DOCTOR ARRESTED - Buenos Aires, Argentina: Carlos Jerez has been jailed because he had healed 13,000 cases of cancer, including terminal cases. Jerez used a maser whose electric output was polarized through an artificial blue sapphire crystal. He also invented a computerized tomographer that detected and indicated the missing chemical elements in the diseased body. His equipment and properties were seized by the secret police and totally destroyed. All of his medical records were confiscated by the Servicio de Informaciones del Estado (SIDE) and his records are being kept by the Secret Police. He is incarcerated at the Prison of San Pedro, 250 kilometers north of Buenos Aires, Argentina.

1981

CARBURETION, POGUE - ULTRA-LEAN CARBURETORS of Northridge, CA, is selling a set of plans for the POGUE carburetor for \$50. (This price is to high). (see 1/7/36)

1981

CARBURETION, WALLACE - Allan Wallaces' experimental carburetor gets 30 mpg at a speed of 55 mph for 60 miles.

1981

CARBURETION, SHELL MOTOR OIL CO. - At SHELL MOTOR OIL Mileage Marathon, Great Britain, a new world record is set at 1368 mpg on a specially built three-wheeler with a 90cc engine using the "sprint & coast" method.

1981

CARBURETION, OGLE -Tom Ogle SOLD OUT his high mileage carburetor to ADVANCE FUEL SYSTEMS of Seattle, WA, for \$250,000 while still retaining 20% interest in his device that got 100 mpg on a 1970 Ford. (see 1977)

1985

CARBURETION - Well, the 1968 FORD MOTOR CO. high-mileage carburetor (26:1) isn't on the market yet. I wonder what happened? (see 1968)

Misc. research & rumors:

1. The mixed chemical stone found in England and secretized by the Queen.? It generated its' own electrical sparks.
2. The Alexander Patent (#3913004) claims 3 watts out for 1 watt in
3. Demonstrations by S. Seike at the Germany Symposium of Gravitational Field J-3J,13 SEIKE Energy. (Nov. 27, 1980)

## NON-CONVENTIONAL ENERGY PATENTS

**BY PAUL BROWN**

Patentee	Number	Title	Class
Tesla, N.	512,340	Coil for Electromagnets	
Stubblefeld, N.	600,457	Electrical Battery	2
Rodgers, J.H.	958,829	Apparatus for HF Currents	1
Tustin, E.B.	961,914	Wireless Lighting	
Tesla, N.	1,061,206	Turbine	
Rodgers, J.H.	1,220,005	Wireless Signaling	1
Bintliff, W.T.	1,237,862	Primer for Gas Engines	4
Rodgers, J.H.	1,303,729	Wireless Signaling	1
Rodgers, J.H.	1,303,730	Radiosignaling System	1
Rodgers, J.H.	1,315,862	Radiosignaling System	1
Rodgers, J.H.	1,316,188	Radiosignaling System	1
Martin, L.H.	1,319,718	Fuel Vaporizer	4
Rodgers, J.H.	1,322,622	Wireless Signaling	1
Rodgers, J.H.	1,349,103	Radiosignaling System	1
Rodgers, J.H.	1,349,104	Radiosignaling System	1
Rodgers, J.H.	1,387,736	Radiosignaling System	1
Rodgers, J.H.	1,395,454	Radiosignaling System	1
Rodgers, J.H.	1,510,799	Loop Aerial	1
Quisling, S.	1,743,978	Propulsion Mechanism	
Lilienfeld, J.E.	1,745,175	Current Control	5
Britten, C.J.	1,826,727	Radio Apparatus	2
Powell, A.	1,835,721	Magnetic Motor	6
Worthington, H.L.	1,859,643	Magnetic Motor	6
Bougon, G.H.	1,859,764	Magnetic Device	6
Lilienfeld, J.E.	1,877,140	Current Amplifier	5
Lilienfeld, J.E.	1,900,018	Current Controller	5
Lakhovsky, G.	1,962,565	Multiple Freq. Oscillator	1
Poysa, J.W.	1,963,213	Magnetic Motor	6
Brown, T.T.	1,974,483	Electrostatic Motor	7
Laskowitz, I.B.	2,009,780	Centrifugal Thrust	8
Neff, T.	2,088,115	Reaction Motor	8
Coanda, H.	2,108,652	Propelling Device	9
Coanda, H.	2,157,281	Propelling Device	9
Nowlin, A.C.	2,350,248	Directional Force	8
Lakhovsky, G.	2,351,055	Multiple Freq. Tube	1
Lovell, W.V.	2,400,869	Electromagnet	
Brown, T.T.	2,417,347	Vibration Damper	7
Moray, T.H.	2,460,707	Electrotherapeutic Device	2
Heironymus, T.G.	2,482,773	Material Emanations	
Mueller, R.K.	2,488,734	Dynamo Transformer	10
Shaw, H.N.	2,553,875	Electric Heater	2



Sturtevant, G.R.	2,560,260	Magnetic Suspension	11
Liamozas, J.D.	2,636,340	Direct Push Unit	8
Crump, L.R.	2,813,242	Atmospheric Energy	2
Dean, N.L.	2,886,976	Inertial Drive	8
Carr, O.T,	2,912,244	Amusement Device	7
Coanda, H.	2,939,650	Airplane Wing	9
Coanda, H.	2,939,654	Lift & Direction Control	9
Brown, T.T.	2,949,550	Electrokinetic Device	7
Brown, T.T.	3,018,394	Electrokinetic Transducer	7
Brown, T.T.	3,022,430	Electrokinetic Generator	7
Coleman, W.J.	3,071,705	Electrostatic Propulsion	7
Hill, G.A.	3,095,163	Ion Propulsion	7
Dudley, H.C.	3,095,167	Ionic Propulsion	7
Rice, W.A.	3,106,058	Propulsion System	7
Hagen, G.E.	3,120,363	Flying Apparatus	7
Deseversky, A.P.	3,130,945	Ionocraft	7
Gradecak, V.	3,177,654	Electric Propulsion	7
Dean, N.L.	3,182,517	Variable Oscillator	8
Brown, T.T.	3,187,206	Electrokinetic Device	7
Kellogg, H.D.	3,203,644	Inertial Drive	8
Wells, F.W.	3,227,427	Carburetion System	
Bahnson, A.H.	3,227,901	Electrical Thrust	7
Vogel, S.F.	3,259,784	Non-Inductive Wiring	
Coanda, H.	3,261,162	Lifting Device	9
Farrall, A.W.	3,266,233	Propulsion Device	8
Davis, R.L.	3,267,406	Non-Inductive Resistor	
Priore, A.	3,280,816	Radiation Source	
Brown, T.T.	3,296,491	Ionic Device	7
Lennon, C.D.	3,312,425	Aircraft	7
King, J.F.	3,322,374	MHD Propulsion	7
Subieta, G.C.	3,368,141	P.M. Transformer	
Priore, A.	3,368,155	Radiation Source	
Kromrey, R.	3,374,376	Rotary Converter	2
DiBella, A.	3,404,854	Inertial Propulsion	8
Dzung, L.S.	3,428,835	MHD Generator	12
Klein, G.	3,428,836	MHD Generator	12
Favereau, J.R	3,428,927	Magnetic Field Source	
Bollee, B.	3,433,981	Electrostatic Motor	3
Bollee, B.	3,436,630	Electrostatic Motor	3
Kussy, F.W	3,437,885	Electromagnet	
Grunwald, E.	3,441,755	DC Machine	2
Painton, R.C.	3,441,761	Ironless Rotor Motor	2
Hammel, J.E.	3,441,775	Plasma Confinement	13
Dowsett, B.O.	3,443,134	Homopolar Machine	2
Larson, R.C.	3,449,098	Fuel Atomizer	4
Okress, E.C.	3,464,207	Corona Vehicle	7
Herb, R.B.	3,469,118	HV Electrostatic Gen.	
Jines, J.E.	3,469,130	Magnetic Motor	6
Boltinghouse, J.	3,482,455	Electrostatic Levitation	11
Auweele, A.J.	3,492,881	Prime Mover	8

Drell, S.D.	3,495,791	Electro-Mech Propulsion	7
Engelberger, J.F	3,504,868	Space Propulsion	7
Brown, T.T.	3,518,462	Fluid Flow Control	7
Halvorson, E.M.	3,530,617	Vibration Propulsion	8
DeRuggeris, J.	3,535,572	Alternator	2
Young, H.W.	3,555,915	Directional Force	8
Matyas, L.B.	3,584,515	Propulsion Apparatus	
Sheridan, F.R.	3,609,425	Magnet Motor	6
Skinner, S.M.	3,610,970	Energy Converter	2
Hooper, W.J.	3,610,971	Motional Field Gen.	14
Wallace, H.W.	3,626,605	Gravity Generator	14
Wallace, H.W.	3,626,606	Dynamic Field Gen.	14
Hooper, W.J.	3,656,013	Motional Field Gen	14
DeBroquevie lie	3,662,554	ELM Propulsion	7
Papp, J.	3,670,494	Atomic E. to Kinetic	2
Cook, R.L.	3,683,707	Propulsion System	8
Guderjahn, C.A.	3,717,103	Magnetic Suspension	11
DeRuggeris, J	3,728,564	Alternator	2
Farr, R.S.	3,738,334	Emission Reducer	4
Bernstein, J	3,748,502	Resonant Energy Converter	
Babington, R.S.	3,751,210	Fuel Vaporizer	4
Ognyanov, M.	3,766,094	Semiconductive Compositions	
Eastham, J.F.	3,770,995	Linear Induction Motor	11
Schaeffer, K.	3,791,349	Steam Generator	
Estrade, F.	3,807,244	Kinetic Energy Device	8
Zubris, J.R.	3,809,978	Electric Vehicle Circuit	2
Kiniski, Z.C.	3,811,058	Magnetic Motor	6
Wallace, H.W.	3,823,570	Heat Pump	
Eastham, J.F.	3,836,799	ELM Levitation	11
Dotto, G.A.	3,839,771	Thermionic Couple	
Babington, R.S.	3,864,326	Nebulizing Device	4
Ecklin, J.W.	3,879,622	Magnet Motion Converter	6
Freeman, A.M.	3,886,919	Fuel Gasifier	4
Brown, C.M.	3,890,161	Diode Array	2
Gray, E.V.	3,890,548	Pulsed Discharge Engine	2
Kinnison, R.W.	3,899,703	Magnet Motion Converter	6
Alexander, R.W.	3,913,004	Alternator	2
Davis, A.R.	3,947,533	Mag. Field Oscillator	
Putt, J.W.	3,992,132	Energy Converter	6
Yater, J.C.	4,004,210	Thermoelectric Converter	2
DeRivas, E.	4,006,401	Electromagnetic Generator	2
Scholin, H.W.	4,011,477	Magnet Motor	6
Eastham, J.F.	4,013,906	ELM Levitation	11
Brown, Y.	4,014,777	Welder	
Hubert, R.D.	4,020,815	Air Heater for IC Engine	4
Teal, B.R.	4,024,421	Magnetic Engine	6
Clover, L.W.	4,025,807	ELM Motor	6
Richardson, F.	4,077,001	ELM Converter	
Kelly, D.A.	4,082,969	Magnetic Torque Converter	6
Zinsser, R.G.	4,085,384	Pulse Generator	2

Bernecker, G.B.	4,086,893	Carburetor	4
Teal, B.R.	4,093,880	Magnetic Engine	6
Harpinan, W.B.	4,112,889	Fuel System	4
Putt, J.M.	4,121,139	Magnetic Propulsion	
Blue, A.H.	4,124,463	Electrolytic Cell	4
Johnson, H.R.	4,151,431	Magnet Motor	6
Wichman, R.D.	4,151,821	Fuel Supply System	4
Moore, J.C.	4,153,653	Fuel Induction System	4
Yeh, G.C.	4,163,367	Compressed Fluid Propulsion	
Kelly, D.A.	4,167,684	Magnet Torque Multiplier	6
Kelly, D.A.	4,179,633	Magnetic Wheel Drive	6
Sanada, M.	4,181,111	Fuel feed Device	4
Anderson, E.R.	4,182,748	Dissociation of Water	
Perepolkin, J	4,204,485	Fuel Vaporizer	4
Jones, J.M.	4,205,654	Solar Energy Unit	
Stahovic, R.F.	4,207,773	Magnetic Piston Motor	6
Leibow, B.	4,208,592	Air Power System	
Levy, D.D.	4,213,432	Fuel Vaporizer	4
Hickox, B.	4,249,096	Dynamo	2
Putt, J.M.	4,249,115	Magnetic Propulsion	
Ehresmann, E.	4,249,501	Fuel System	4
Greenspan, P.D.	4,251,992	Pneumatic Propulsion	
Parietti, P.	4,289,106	Fuel Pressure Regulator	4
Kuroki, S.	4,305,024	Magnetic Motor	6
Barber, S.	4,323,046	Dual Fuel System	4
Ab, E.A.	4,325,005	Ion Accelerator	
Igashira, T.	4,325,344	Fuel Evaporator	4
Bourgoin, R.C.	4,325,795	Ambient Superconductor	
Jacobi, E.F.	4,326,013	Energy System	
Burchett, L.R.	4,326,491	Fuel Heater	4
Hattori, T.	4,345,569	Intake System	4
Adams, J.W.	4,372,280	Fuel Vaporizer	4
Marhanka, F.D.	4,390,605	Source of Electricity	2
Puharich, H.K.	4,394,230	Water Decomposer	
Gelinas, R.C.	4,429,280	Scaler Demodulator	
Gelinas, R.C.	4,429,288	Scaler Modulator	
Gelinas, R.C.	4,432,098	Scaler Transmitter	
Gelinas, R.C.	4,447,779	Scaler Receiver	
Young, C.G.	4,449,509	Gaseous Fuel Carb	4
Harvey, R.	4,498,447	Fuel Vaporizer	4
Glass, J.W.	4,452,215	Fuel System	4
Ecklin, J.	4,567,407	Overunity Generator	2
Brown, P.	4,858,582	Fuel Preconditioner	4
Hyde, W.W.	4,897,592	Electrostatic Generator	2
Pasichinskyj, M.	4,904,926	Electrical Generator	2
Pinkerton, J.F.	4,945,273	Electrical Machine	2
Shoulders, K.R.	5,018,180	Energy Converter	2
Brown, P.	5,074,273	Fuel Preconditioner	4
Brown, P.	5,092,303	Fuel Preconditioner	4

## Foreign Patents

British	Brown, T.T.	#300311	Gravitor	7
British	Frederick, C.	#1310990	Craft	7
European	Thomson, B.	#0128008	Kinetic Lift Device	8
European		#149057A1		2
France	Pages, J.M.	#1253902	Flight Engine	7
France	Priore, A.	#1342772		
France	Gay, H.	#2486327	P.M. Self-Movement Device	6
German	Kunel, H.	#3024814	P.M. Flux Generator	2

- 1 *High Frequency Resonant Systems*
- 2 *Electricity source, Free Energy, overunity Performance*
- 3 *Electrostatics, Atmospheric Electricity*
- 4 *Air/Fuel Preconditioners for Increased Efficiency & Economy*
- 5 *Transistors-Moray related*
- 6 *Permanent Magnet Motors*
- 7 *Ionic Propulsion, Biefeld-Brown Effect, Electromagnetic Propulsion*
- 8 *Reactionless or Inertial Propulsion*
- 9 *Coanda.Effect*
- 10 *Variable Reluctance Alternators*
- 11 *Electromagnetic Levitation or Suspension*
- 12 *MHD Generators*
- 13 *Plasma Confinement for Fusion*
- 14 *Electrically Induced Gravity Field Generators*

## FUEL ECONOMY PATENTS

**BY PAUL BROWN**

Number	Date	Patentee
165,564	7-13-1875	Gray
474,838	5-17-1892	Lambert
610,159	8-30-1898	Speer
844,996	2-19-1907	Colbath
890,970	6-16-1908	Durr
965,867	8-02-1910	
993,516	5-30-1911	
1,004,594	11-19-1912	Stroud
1,051,122	1- -1913	Krayer
1,065,370	6-24-1923	Johnston
1,103,789	7-14-1914	Macey
1,121,137	12-15-1914	Schoomaker
1,150,115	8-17-1915	Heinz
1,177,904	4-04-1916	Stanley
1,182,714	5-09-1916	Schmidt
1,191,097	7-11-1916	Speirs
1,195,315	8-22-1916	Williams
1,259,898		
1,273,030	7-16-1918	Campbell
1,281,961		
1,325,998	12-23-1918	Schmid
1,327,205	1-06-1920	Heslewood
1,373,426	10-11-1921	Campbell
1,392,473	10-04-1921	Ball
1,518,572	12-09-1924	Croon
1,530,882	3- -1925	Chapin
1,562,670		
1,585,094	5-18-1926	Hendricks
1,610,152	12-07-1926	Renard
1,679,742	8-07-1928	Ralston
1,690,962	11-06-1928	Allen
1,711,292	5-30-1929	Strong
1,725,111	6-20-1929	Sweeny
1,731,135	10-08-1929	Hutchinson
1,734,723	11-05-1929	Gildehaus
1,750,354	3-11-1930	Pogue
1,752,506	4-01-1930	Portail
1,757,920		
1,763,508	6-10-1930	Fowler
1,763,654	6-17-1930	Hutchinson
1,798,065	3-24-1931	Clark

1,809,242		
1,820,512	5-12-1932	
1,834,766	12-01-1931	Briggs
1,841,778		
1,858,853	5-12-1932	DeFrance
1,938,497	12-05-1933	Pogue
1,941,862	1-02-1934	Heitger
1,952,281		
1,968,698	7-31-1934	Meyer
1,970,169	8-14-1934	Godward
1,972,874	9-11-1934	Dobbs
1,997,497	4-09-1935	Pogue
2,000,498	5-07-1935	Rickabaugh
2,006,676		
2,014,306	9-17-1935	Rosler
2,014,396		
2,014,907	9-17-1935	Myers
2,026,798	1-07-1936	Pogue
2,028,333	1-21-1936	Johnston
3,038,031	4-21-1936	Doyle
2,040,020		
2,061,043	11-17-1937	Phillip
2,073,649	3-16-1937	Price
2,109,743	3-01-1938	Faverty
2,116,718	5-10-1938	Stubbs
2,218,922	10-22-1940	Newberry
2,236,595		
2,262,013	11-11-1941	Lang
2,262,904	11-18-1941	Pickering
2,290,893	7-28-1942	Phillips
2,310,739	2-09-1943	Lang
2,312,151	2- -1943	Crabtree
2,314,131	3-16-1943	McLindon
2,338,044		
2,373,032		
2,384,609	9-11-1945	Devries
2,453,595	11-09-1948	Rosenthal
2,460,528		
2,529,665		
2,531,661		
2,650,582		
9-01-1953		Green
2,658,489		
2,702,694	2-22-1955	Featherson
2,742,886	4-24-1956	McPhearson
2,761,660		
2,797,072	6-25-1957	Lucas
2,801,086		
2,821,843	2-04-1958	Mengelkamp
2,879,045	3-24-1959	Anderson

2,939,775		
2,982,528	5-02-1961	Shelton
3,001,519	9- -1961	Dietrich
3,049,850	8-21-1962	Smith
3,067,020		
3,081,160		
3,171,467		
3,221,724	12- -1965	Wentworth
3,227,427		
3,273,983	9-20-1966	Minoza
3,279,770		
3,285,588	11-15-1966	Ruddle
3,286,703	11-22-1966	Rawles
3,294,381	12-27-1966	Schwartz
3,336,734	8-22-1967	Schultz
3,338,223	8-29-1967	Williams
3,386,710		
3,395,681	8- -1968	Walker
3,411,489	11-19-1968	Kruger
3,432,281	3-11-1969	Meierbachtol
3,433,608	3-18-1969	Epifanio
3,447,514	6-23-1969	Trafford
3,496,919		
3,630,698	12-28-1971	Baldwin
3,633,533	1- -1972	Holzappel
3,640,256	2- -1972	Low
3,653,643	4-04-1972	Tucker
3,685,808	8-22-1972	Bodai
3,713,429	1-30-1973	Dwyre
3,716,040	2- -1973	Herpin
3,728,092	4- -1973	Gorman
3,741,180	6-26-1973	Richbaum
3,747,901		
3,749,318		
3,749,736	7- -1973	Aim
3,752,134	8- -1973	Hollis
3,752,451		
3,759,234	9- -1973	Buckton
3,763,838	12-23-1973	Lindsay
3,763,839		Aiquist
3,765,382		
3,817,233	6-18-1974	Kihn
3,851,021		
3,851,633	12-01-1974	Shih
3,854,463	12- -1974	Burden
3,855,372	12-17-1974	Koch
3,872,849	3-25-1975	Chester
3,874,353	4- -1975	Wooldridge
3,884,204		Krautwurst
3,888,223	6- -1975	Mondt

3,892,213		Cole
3,907,946	9-23-1975	Brown
3,911,881	10- -1975	Lee
3,927,651	1-13-1975	Harrow
3,931,801	1- -1976	Rose
3,945,352	3-23-1976	Reimuller
3,957,029		
3,968,775	7- -1976	Harpman
3,987,132		
3,996,906		Bubnaik
3,996,907		Marsee
3,999,526	12-28-1976	Asfar
4,008,692	2-22-1977	Shinohara
4,015,569	5-05-1977	Leshner
4,020,811	11-18-1974	LaForce
4,022,172	12-29-1975	Fingerroot
4,031,874	6-28-1977	Alwins
4,031,875	6-28-1977	Tyler
4,047,512		Hamberg
4,085,719		Hamberg
4,085,721		Vardi
4,086,893		Barnecker
4,092,963	6-06-1978	Vrooman
4,098,236		
4,100,899	7-18-1978	Chilton
4,103,658	8-01-1978	Bernecker
4,108,125		
4,108,126		
4,130,582	2-13-1979	Collins
4,140,094		
4,147,142	4-03-1979	Little
4,151,821	5-01-1979	Wichman
4,152,653		
4,161,931	7- -1979	Giardini
4,177,779	12- -1979	Ogle
4,178,897	12-18-1979	Stream
4,181,111		
4,204,485		Perepolkin
4,213,432		
4,249,501		
4,325,344	4- -1982	Igashira
4,326,491		
4,345,569		Hattori
4,372,280		
4,947,512		



## **ELECTROMAGNETIC OR IONIC PROPULSION SYSTEMS**

**BY PAUL BROWN**

---

The use of atomic energy for rocket propulsion was proposed long before nuclear fission was discovered in 1939. As early as 1906, Robert Goddard published papers describing the energy inherent in a unit mass of radium. Scientists and engineers were neither able to efficiently direct the energy released to produce thrust nor produce more energy by spontaneous disintegrations in radium during that time period. Gaetano Arturo Crocco, in 1923, suggested directing radium's alpha particles using a magnetic field to produce thrust. In 1924, Soviet scientist K.E. Tsiolkowski, decided that it was impractical to use radium for rocket propulsion for the same reasons Goddard had deduced 18 years earlier, i.e., the energy release is low and slow and the cost too high.

Interest in non-chemical spacecraft propulsion systems has been rekindled with the recent ambitious manned space missions planned by NASA's Space Exploration Initiative. Deep space missions will require more energy than is practically available from chemical systems. Nuclear reactors could provide power for electric propulsion systems which would yield a greater specific power due to the fact that nuclear energy is several orders of magnitude greater than chemical energy. Future development of electric spacecraft propulsion systems can build on the technology and experience of those past efforts.

In case some of you may be unfamiliar with space propulsion issues, nuclear/electric propulsion is of interest because it offers a significant advancement in propulsion efficiency. Specific impulse is a measure of the efficiency with which a propellant rocket system provides propulsive energy. Thus, the higher the specific impulse the less propellant is needed to perform a given mission.

Specific impulse is related to the square root of propellant temperature divided by the molecular weight of the propellant. Compared to chemical rockets which are limited by the molecular weight of their combustion products, the specific impulse of the simplest nuclear/electric rocket concepts can exceed that of chemical rockets by two or three times. Some of the specific impulse advantage is lost because of the greater nuclear engine weight and the complications of radiation. But for high payload missions to the moon or the nearest planets, there remains a large advantage in terms of reduced mission mass and trip times.

A revived nuclear/electric propulsion program certainly faces challenges but, a solid base of technology has been established on which mission planners and technology developers can build with high confidence.

The outstanding accomplishments in space of the Soviet Union, United States, and other countries are stepping stones to very ambitious manned Mars missions and the colonization of the moon.

The following list is not complete but does provide a basis for further investigation.

<b>Patent #</b>	<b>Date</b>	<b>Patentee</b>	<b>Title</b>
1,974,483	9-25-34	Brown, T.T.	Electrostatic Motor
2,417,347	3-11-47	Brown, T.T.	Vibration Damper
2,912,244	11-10-59	Carr, O.T.	Amusement Device
2,949,550	8-16-60	Brown, T.T.	Lift & Direction Control
2,958,790	11-01-60	Bahnson, A. H.	Electrical Thrust Device
2,997,013	8-12-61	Rice, W.A.	Propulsion System
3,018,394	1-23-62	Brown, T.T.	Electrokinetic Transducer
3,022,430	2-20-62	Brown, T.T.	Electrokinetic Generator
3,071,705	1-01-63	Coleman, W.J.	Electrostatic Propulsion
3,095,163	6-25-63	Hill, G.A.	Ion Propulsion
3,095,167	6-25-63	Dudley, H.C.	Ionic Propulsion
3,106,058	10-08-63	Rice, W.A.	Propulsion System
3,120,363	2-04-64	Hagen, G.E.	Flying Apparatus
3,130,945	4-28-64	DeSeversky, A.P.	Ionocraft
3,177,654	4-13-65	Gradecak, V.	Electric Propulsion
3,187,206	6-01-65	Brown, T.T.	Electrokinetic Device
3,223,038	-65	Bahnson, A.H.	Electrical Thrust
3,227,901	1-04-66	Bahnson, A.H.	Electrical Thrust
3,263,102	7-26-66	Bahnson, A. H.	Electrical Thrust
3,312,425	4-04-67	Lennon, C.D.	Aircraft
3,322,374	5-30-67	King, J.F.	MHD Propulsion
3,464,207	9-02-69	Okress, E.C.	Corona Vehicle
3,495,791	2-17-70	Drell, S.D.	Electro-Mech Propulsion
3,504,868	4-07-70	Engelberger, J.	Space Propulsion
3,518,462	6-30-70	Brown, T.T.	Fluid Flow Control
3, 662,554	5-16-72	DeBroqueville	ELM Propulsion
4,663,932	-87	Cox, J.	Force Field Propulsion
4,874,346	-89	Wachspress	Magnetic Levitator

The following bibliography may also be of use:

Alfven, H., Spacecraft Propulsion: New Methods, Science, 167-168, April 14, 1972

- Asker, J., Moon/Mars Prospects May Hinge on Nuclear Propulsion Bond, A., Problems of Interstellar Propulsion, Spaceflight, 245-251, July 1971
- Brown, T., How I Control Gravitation, Science & Invention, Aug. 1929
- Brown, T., Notebooks, William Moore Publications, 1987
- Cady, W., An Investigation Relative to Thomas Townsend Brown, Office of Naval Research, declassified Oct. 1, 1952
- Cleaver, A., Electro-Gravitics: What It Is Or Might Be, J. Brit. Interplanetary Soc. Vol. 16, 84-94, 1957
- Cleaver, A., Interplanetary Flight: Is The Rocket The Only Answer?, J. Brit. Interplanetary Soc., Vol. 6, No. 5, 127-148, June 1947
- Corliss, W.R., Propulsion Systems Using Natural Force Fields, Propulsion Systems for Space Flight, McGraw-Hill, 1960, 255-261
- Cox, J., Electromagnetic Propulsion Without Ionization, AIAA 16<sup>th</sup> Joint Propulsion Conference, paper 80-1235, Hartford, CT, July 1980
- Cox, J., Shuttle Propulsion Using Electromagnetic Force Fields, AIAA 17th Joint Propulsion Conference, July 27-29, 1981, Colorado Springs, CO.
- COX, J., The Space Drive Handbook, P.O. Box 793, Pomona, CA 91768, 1961
- Cravens, D., Electric Propulsion Study, Parts 1-4, Astronautics Laboratory (AFSC) Report AL-TR-89-040, Aug. 1990
- Dudley, H., The Electric Field Rocket, Analog Science Fact & Fiction, 83-94, Nov. 1960, Experiments by Dudley.
- Fantel, H., Major de Seversky's Ion-Propelled Aircraft, Pop. Mech. p. 58, Aug. 1964
- Forward, R., Advanced Space Propulsion Study, Astronautics Laboratory, Report AFAL TR-87-070, Oct. 1987
- Forward, H., 21st Century Space Propulsion Study Addendum, Phillips Laboratory Report PL-TR-91-3022, June 1991
- Gravity Research Group, Electrogravitics Systems: An Examination of Electrostatic Motion, Dynamic Counterbary and Barycentric Control, Aviation Studies LTD, London, Feb. 1956
- Holt, A., Coherent Field and Energy Resonance System, patent disclosure, NASA Case No. MSC-18765, Feb. 1980.
- Holt, A., Effects of Hydromagnetic Waves on Magnetic Field Line Merging, Master's Thesis, Univ. Houston at Clear Lake City, May 1979.
- Holt, A., Field Resonance Propulsion Concept, NASA JSC-16073, Aug. 1979.
- Holt, A., Hydromagnetics and Future Propulsion Systems, AIAA Student Journal, Spring 1980.

Holt, A., Prospects for a Breakthrough in Field Dependent Propulsion, AIAA 16th Joint Propulsion Conference, June 30-July 2, 1980D Hartford, Conn.

INTEL, Towards Flight Without Stress or Strain...or Weight, Interavia Vol. 11, No. 5, 372-374, 1956, T.T. Brown work.

Jones, R., The Force Field Propulsion System, Rocket Exchange, Summer 1968, p. 15-16

Kraus, A., Proposed Method of Accelerating Space Vehicles to Relativistic Velocities, Bull. Amer. Phys. Soc. 6, p. 516, 1961

LaViolette, P., Electrogravitics: An Energy-Efficient Means of Spacecraft Propulsion

Papailiou, D., Frontiers in Propulsion Research, Tech. Memo. 33-722, JPL, Pasadena, CA, 1975

Stine, H., Report on the Electric Field Rocket, Analog Science Fact & Fiction, 83-96, Oct. 1961, Experiments of Dudley.

Talley, R., 21st Century Propulsion Concept-I, II, and III, April 1988, Sept. 1988, May 1991, Phillips Laboratory #PL-TR-91-3009

## PCV JAR PLANS

Here is a device that you can build that will improve your gas mileage by at least 25%, and also keep your oil, engine and spark plugs cleaner, thus allowing your engine to have a much longer life. The device can be made for a total cost of about \$12.00, and about two hours of labor.

The device consists of a 1 quart jar, a small V8 fruit juice can or similar container, window screen, BBs', hoses, washers and clamps.

The device is installed in between the PCV valve of your automobile engine and the vacuum source the PCV valve is normally connected to.

The device condenses the oily vapors normally sucked into the combustion chamber as part of the pollution control systems, in a container of BBs', where the vapors condense around the BBs', and drain into the bottom of the jar. If you can find them, use glass beads the same size of the BBs'. I have been unable to find any, but I know that they are made.

Blow by gases, containing gasoline vapors, are drawn back into the engine for burning. Combustion efficiency is improved as a result of the oily vapors collected in the jar, rather than contaminating the fuel/air charge in the combustion chamber.

Obtain a 1 quart jar, preferably with a wide mouth. The wide mouth is necessary for the juice can containing the BBs' to fit in the jar. Being careful not to damage the sealing gasket of the jar lid, locate and cut a 1/2 inch hole in the very center of the jar lid.

Locate and cut another 1/2 inch hole midway between the hole in the center of the lid and the outside edge of the jar lid. At this point, the jar lid has two, 1/2 inch holes cut in it. Try to keep the holes neat without any excess metal protruding above or below the lid surface.

Obtain a length of 1/2 inch, all threaded pipe, and 6, 1/2" nuts. I use the pipe and nuts, that are used in lamps and lighting fixtures, and buy it at lamp shops. Some of this pipe has a seam in it, which you don't want. This device must be air tight, as engine vacuum is connected. Cut 1, 2-1/2 inch length and 1, 1-1/2 length.

Cut the end with the pouring hole, out of the small V8 juice can. Wash out and dry the can. Cut a 1/2 inch hole in the center of the juice can. Using 1/2 inch nuts, and fender washers and silicone gasket sealer (you'll have to enlarge the holes in the washers to fit the 1/2 inch pipe), install the 2-1/2 inch length of pipe in the V8 juice can.

Leave about two threads of the pipe, showing down inside the can. Use the fender washers on both side of the juice can to provide support. This can will be eventually filled with BBs', and the washers are necessary because of the weight.

Take the 1-1/2 inch length of threaded pipe, 2 nuts and some silicone gasket sealer, and install in the hole of the jar lid, NOT the hole in the very center. Leave 2 or 3 threads of the pipe showing on the underside of the jar lid.

Back to the juice can. Cut a piece of aluminum window screen to neatly fit the inside of the juice can, and push it down into the juice can, leaving no gaps for the BBs' to roll into the threaded pipe. Fill the can completely, with copper plated BBs'.

Take another piece of aluminum window screen, and pull it over the end of the juice can, leaving about a 1/2 inch skirt of screen. Using a large worm gear type hose clamp, gently tighten the clamp, snugging the screen to the outside surface of the juice can. You have to be careful here. You want to tighten the clamp just enough where the juice can STARTS to deform.

Install this can full of BBs' in the center hole of the jar lid, using washers and nuts. Leave about 1/2 inch of space between the top of the juice can and the other pipe installed in the jar lid, to allow the blow-by gasses to exit the jar.

Install 1/2 inch elbow on both pipes protruding from the top of the jar lid. Install a 1-1/2 inch piece of pipe into each elbow.

Obtain 1/2 automobile heater hose, and connect the jar to the engine as follows:

- o From the center pipe of the jar lid, connect to the PCV valve. If the hose is too large, use a worm gear clamp to secure the hose.
- o From the other pipe in the jar lid, connect a 1/2 inch section of heater hose to the vacuum source of the engine.

**MAKE SURE THAT THE JAR IS ABSOLUTELY AIR TIGHT !!** If not, you will know what is meant by a vacuum leak.

Now for the hardest part:

You want to locate a spot in the engine compartment to mount a 1 pound coffee can, in which to hold the jar. Try to locate a place where the hoses can be kept as short as possible.

Cut several holes in the bottom of the coffee can to let any water drain out that may get in the can after a hard rain or that you have driven through. Cut a couple of pieces of the hose to wedge between the coffee can and the jar, to keep it snug and not bouncing around.

To make this assembly blend into the engine compartment, paint the jar lid, juice can and the coffee can, flat black. Consider using hoses the same color as the other engine compartment hoses.

Depending on how far you drive, the jar will probably require emptying about once a month. Vehicles which are driven short distances and the engine never really gets up to maximum temperature, will require that the jar be emptied about once a week.

The jar will contain mostly water, as a result of condensation that takes place in the oil pan. The liquid in the jar contains unburned hydrocarbons, water and sludge. The liquid is also mildly acidic, as a result of the water vapor and the unburned hydrocarbons, combining. Some people have noticed a slight burning sensation, if the liquid gets on the skin.

About every 30,000 miles or so, wash out the BBs' with varsol to keep the passage ways open.

Your engine will stay cleaner and last much longer. Some people have claimed they have gone 500,000 miles without a rebuild. Three hundred thousand mile claims are common. The most mileage increase heard, has been 40%. Twenty five percent is much more common.

You will not believe the sludge and "gunk" that builds up in the jar. I broke an oil pump shaft in an engine with 185,000 miles on it, and when the oil pan was pulled, there wasn't any sludge or buildup. I installed the jar when the engine had about 72,000 miles on it. Additionally, the emission test readings are much lower.

This is one project where you'll get a return on your money and efforts, very quickly.

## CHAIN REACTION

### FROM THE MOVIE

---

The movie is about research into how to produce hydrogen from water as efficiently as possible, in fact, the goal is to make a sonoluminescent bubble that sustains itself.

The idea is to produce a sonoluminescent bubble and target it using a high powered laser, but the bubble collapses when the laser beam is shut down.

The key to the overunity process is accidentally discovered when, while machining a piece of metal in a lathe, the sonic squeal causes a sonoluminescent bubble to increase in intensity.

The movie opens on a lecture by Dr. Alistair Barclay on why the world needs a new fuel source;

"We're running out of time. We have polluted and peopled this planet to the brink of extinction."

"We are destroying our world at a suicidal pace. We need a POLLUTION REVOLUTION and it's not going to be easy because the world is ADDICTED to petroleum."

"We have limited resources and we go to war to protect them. We need a new technology and this technology can't be sold, it must be given away, to everyone."

"We are in sight of a dream, there is a solution, the answer is all around us, it's right here, water, H<sub>2</sub>O, two parts hydrogen, 1 part oxygen."

"There is enough energy in this glass of water to power the city of Chicago for the next few weeks, it's the hydrogen we're after."

"This is what happens when we burn it, (lights a serious hydrogen flame, though it burned orange, hydrogen when burning is INVISIBLE)."

"It's perfectly clean, and you can burn it when you want to, in a car, in a turbine, or in your own basement power supply, right next to your water heater."

"But what if we could release this energy efficiently, we will transform the world, maybe we start to put an end to war. Of course, we have to make it work first.."



Later in the movie, agent provocateur Lyman Shannon is explaining why the world cannot have free energy yet

"Alister was a dreamer, clean air, free energy, noble concepts, but we live on a planet that's addicted to petroleum. "

"Now what happens if you dump free energy onto the world market, stock markets around the world would plummet, our own economy would collapse overnight, recession, unemployment, war....the world is speeding up too fast, we can barely hold on as it is."

To which Eddie Kosalovitch replies, "You're right, it's not working! That's why we gotta try something else, not bury the technology, but let it out!"

Lyman Shannon says, "You let it out, but you let it out at a pace the world can absorb."

Eddie Kosalovitch responds with, "It can absorb it NOW!"

## PRODUCING HYDROGEN AT 1.24 VOLTS

The following can be quite dangerous and is being provided simply for information, if you choose to experiment with the production of hydrogen from water, you take full responsibility for your own actions.

Here's a little experiment that even a child can safely perform that proves that there is no 'minimum voltage' for splitting water into hydrogen and oxygen.

The supposed minimum hydrolysis voltage is 1.24 volts. According to standard theory, no reaction should take place at room temperature below this voltage.

This theoretical figure was determined by taking the energy released per mole when hydrogen is burned. Using that figure, and knowing how many amp hours are needed to produce 1 mole of gas, they calculated the theoretical minimum voltage.

In other words, this figure was not determined by first-hand experimentation.

Ok, here's how to do it:

1. fill a small jar with tap water and in it dissolve table salt until reaching full saturation.

2. Get two pieces of steel to use as electrodes. Two short pieces of 1 inch wide flat stock were used in the original experiment. They were spaced about 1/8 inch apart.

3. Hook up a 1.5 volt dry-cell battery to the two plates using a couple of test leads and then measure the voltage across the cell plates. You should see some gas coming off the electrodes and it'll be fizzing. (my measurement showed 1.51 volts under load)

4. Next, connect a small silicon rectifier diode in series with the battery and cell. The particular diode I had available dropped the circuit voltage by about .5 volts. The current will be quite a bit lower than it was, and the gas production will be quite a bit slower. But, you should be able to see and hear the bubbles coming off the plates. (my cell voltage was 1.05 volts during this part of the test.)

Congratulations! Your cell voltage should be lower than 1.24 volts, yet you are still producing hydrogen and oxygen gas!

At these lower voltages, you will be producing gas at greater than 100% efficiency according to standard hydrolysis theory!

The reaction in this voltage range is also endothermic. Go figure.

## FUEL FROM WATER

You can make your own hydrogen plant right in your own back yard to power your lawn mower, to power a Generator, to provide heating and cooking gas for your home and garage. You can make some to run your car but it's a little more complicated and dangerous. HYDROGEN IS HIGHLY EXPLOSIVE but can safely be used if you are careful and do it right.

**WARNING** - Leaking hydrogen could cause an explosion. Make sure you vent the oxygen at least 50 feet from the Hydrogen. KEEP ALL FLAMES AND SPARKS AWAY FROM THE ELECTROLYSER CONTAINER WHEN IT IS IN OPERATION. MAKE SURE ALL ELECTRICAL CONNECTIONS ARE INSULATED. We are not liable or responsible for anything in these plans you build at your own risk. So please be careful.

### How it Works

Hydrogen can be made endlessly from water and as that being the case then the world has far more water than we do fossil fuels. there is oceans full of it. There are widely varying methods of production. Hydrogen has been called the "FOREVER FUEL". When hydrogen is burned water vapor is the main product so if every car in America had it we would have no pollution and it would replenish the earth. Hydrogen can also be made from water in an endless fuel-water cycle.

Hydrogen has the most energy per unit weight of any fuel in the world: about 3 times that of gasoline. Hydrogen is nontoxic and can be safely transported in pipelines for homes and industries. Hydrogen dissipates very quickly in the air. This minimizes explosion hazards.

Hydrogen does have some disadvantages but when you compare it to any other it is a clean and endless amount of fuel Hydrogen does have a higher range of flammability when mixed with air compared to other fuels. This means that it will burn at lower concentrations than any other fuel. also there is no comprising to that of the fuel-less engines. the fuel-less engines are totally free energy system and are very safe to handle and work with. It is best not to waste your time producing hydrogen but to learn all you can about the fuel-less engines and build then. But this is a good science project to work on.

But some of the more disadvantages are: The storing of hydrogen is complex when compared to liquid fuels and other gaseous fuels. Hydrogen has a low energy content on a volume basis: about one-third that of gasoline. Storage devices are bulky. High flame velocity and low ignition energy give hydrogen an advantage in engine performance but present special safety

problems. There are also other safety advantages, in general. Hydrogen is no more dangerous than other fuels.

Hydrogen makes up 90% of the atoms in the universe. It is abundant in interstellar space with an average of about one hydrogen atom per cubic centimeter. but on earth the gas constitutes about 0.2% of the atmosphere. Hydrogen can be produced by passing an electric current through wafer. this method separates the hydrogen from the oxygen in the water molecule in a process called ELECTROLYSIS. Hydrogen on earth is chemically combined with other elements such as oxygen, forming water.

About one billion cubic meters of hydrogen is produced in the U.S.A. every year by our government and industries.

### **Splitting Water - Also called Electrolysis**

Electrolysis is a process of producing hydrogen and oxygen from electricity and water. 2 hydrogen atoms and one oxygen atom are electrically attracted in a molecule of water H<sub>2</sub>O. When an electric current passes through water the chemical bond breaks down. the result is two positively charged hydrogen atoms and one negatively charged oxygen ion. If two oppositely charged electrodes are inserted into the water and a current is passed between them, The negative oxygen ions migrate to the positive electrode which is called the ANODE. While the positively charged hydrogen ions are attracted to the negative electrode (The Cathode).

Half as much oxygen as hydrogen is produced. Electrons are transferred from the anode to the cathode. The electrical resistance of pure water is high But you can lower this resistance by one or all of the following to the water. A SALT LIKE SODIUM CHLORIDE, AN ACID SUCH AS SULFURIC ACID OR A BASE SUCH AS HYDROID.

Salts tend to corrode metals. platinum and phosphoric acid can be used together. But this is expensive. Potassium hydroxide with nickle-iron (stainless steel) electrodes provides the best performance and cost.

4 water molecules are decomposed into 8 positively charged hydrogen ions and 4 negatively charged oxygen ions. each oxygen ion then attaches to one hydrogen ion to form 4 hydrogen ions stay behind. each of them combine with 4 electrons emitted at the cathode to form 4 complete hydrogen atoms. Since hydrogen atoms combine in pairs the 4 hydrogen atoms combine into 2 hydrogen molecules (H<sub>2</sub>). The 4 negatively charged hydroxyl ions are attracted to the positive electrode. The electrolyte allows the ions to be drawn to the anode by increasing the conductivity of the water.

## Separators

Electrolysers consist of 4 things: a container, an electrolyte, an anode (the Positive Electrode), a cathode (The negative electrode), and a separator (the electrolyte consists of water and a chemical that you add to it to allow the conducting of current. You can use a salt or an acid such as in batteries.

The current passes between the electrodes. The separator is placed between the electrodes. It allows the current to pass through but prevents the hydrogen and oxygen generated by the electrolysis process to mix. If both of the hydrogen and the oxygen were allowed to mix during the electrolysis process you would be at high risk of an explosion. mixtures of between 4 to 75% hydrogen in air 4 to 94% of hydrogen in pure oxygen are explosive.

Electrolysers are designed with separators between the anode and the cathode to keep the hydrogen and oxygen from mixing and also to allow ions to be transferred in the liquid electrolyte. Because of this the space between electrodes should be minimized. the separator should be made to with stand the liquids and not let the gases pass through it. you can use materials such as fiber cloth rubber cloth.

Conventional electrolysers operate at temperatures of 167 to 176 degrees F with current densities of around 2 kiloamps per square meter. voltage requirements fall within .9 to 2 volts dc range. The required energy input is 4.8 kwh per cubic meter of hydrogen produced. A homemade electrolyser is about 50 percent efficient. A certain number of watt hours of electricity is converted into about half as many watt-hours of hydrogen. ELECTROLYSER DESIGN A good homemade electrolyser will cost you \$200 or less.

Use only Distilled water. Chlorine in city water corrodes the electrodes. You can use rain water or save the city water in a large container and let it sit for 48 hrs. The electrolyt is 20 to 30% KOH in distilled water. As a 2nd choice baking soda may be used. It requires 4 volts but is safer to use. Use 6 teaspoons per gallon.

Electrode material: stainless steel or nickel containing stainless steel. must be porous like a screen door holes can be less than that like a car oil filter or such just to give you an idea. Electric input: 3-4 volts per cell, 3 to 10 amps. increased currant increases gas output.

The drawing is a cross section of an electrolyser. Note that you can make as many of these as you want the more the better gas you can collect. The drawing shows the basic components of the cell. Note that a nonconducting sleeve separates the cathode from the anode. The 2 electrodes should have equal surface area. The sleeve prevents the hydrogen from combing with the oxygen. The 2 gases must be kept apart to avoid an explosion hazard.

Virtually any nonmetallic container may be used so as long as the gas is not allowed to build up within the electrolyser and generate high pressure. you can use a car battery as your dc source.

**Warning: leaking hydrogen could cause an explosion. vent the oxygen at least 50' from the hydrogen. Keep all flames and sparks away from the electrolyser when in use. Insulate all electrical connections to prevent sparking.**

### **Adding the Electrolyte**

The Electrolyte is the water and baking soda mixture or what ever you choose to use. If you don't have an Ohm Meter than get one. With your Ohm Meter you will need to measure the electrical resistance of the electrolyte, Add your baking soda or potassium Hydroxide until the resistance equals 0.3 ohms, or a 30% solution, Which ever comes first. PLEASE NOTE THAT THE HIGHER THE CURRENT YOU USE FOR YOUR CELL THE LESS ELECTROLYTE YOU WILL NEED TO USE IN IT. (add less baking soda.)

**WARNING:** When the electrolyser (cell) is first used, Hydrogen and Oxygen may be mixed. Discard the first hour's production. Place the electrolyser at a safe distance from habitable buildings. Change the electrolyte every 1,000 hours of use. Ground all circuits. Keep your feet dry when touching the electrolyser.

OUTPUT: At 100% efficiency, and at 12 volts and 40 amps, 480 watts (0.6 horse power) per hour of hydrogen fuel is produced. efficiency is usually about 50%.

This means that output is one-half of what it would be if the unit were 100% efficient. The design as per the diagram may be scaled up for higher output by increasing the height and width of the electrolyser containers. The area of the electrodes, or by increasing the number of cells. Larger designs that use higher current may use cooling fins around the cells so that a blower may dissipate the heat more rapidly to avoid damage to the electrolyte materials.

If 115 volts AC is used for electrolysis, then a transformer and a diode rectifier must be used to change the AC house current to DC current and to step it down to 2 volts with boosted amperage. Using an independent source of electricity such as one of our fuel-less engine's I generator or a solar panel system. The electrical output can be 90% efficient.

A HIGH PRESSURE CELL: The following is a description of a high pressure electrolyser. It is designed to operate at 485 degree's. The gap between the electrodes is 0.12 inch. It uses sanded nickle electrodes to increase surface area. 30 to 50% KOH electrolyte mixture and 1.7 volts per cell. The anode and cathode are made of metal screens covered with oxide ceramic. These are

corrosion resistant and have a high hydraulic resistance with small pores. This feature eliminates the passing of large amounts of gas bubbles.

Using higher temperature's such as this, plastics can not be used, they will melt. In these bodies and tubings the tubings are made of steel-lined with nickle because nickle does not absorb hydrogen as many other metals do. Steel is needed for it's strength but it can not come In contact with the hydrogen. The electrodes are made of coarse screen.

### **Hydrogen Summary**

HYDROGEN fuel is being studied and applied in virtually every way in which conventional fuels are used in domestic non-commercial use.

\* COOKING \* WATER & SPACE REFRIGERATION \* LIGHTING AND GENERATING ELECTRICITY \* HEATING AND COOLING \* TRANSPORTATION \* FARMING

In all these applications, it is far superior to conventional fuels and other synthetic alternatives.

In this brief discussion on hydrogen from water we have tried to give a quick idea and look at the complexity and dangers of making your own hydrogen in your back yard, Yes it can be done and has been done by many but again why waste your time on it other than it can be a fun science experiment or you can make your own weather balloons instead of using helium because hydrogen is lighter than helium.

If you feel you want to tackle this project then we suggest you get more information on the subject from your library. We hope we have enlightened you on the subject of hydrogen. Many people and the government are trying to push the world into using it, Why? When we have Fuel-less machines to give us free energy.



# A ONE CELL ELECTROLYSER

Splits The Water - Separates Hydrogen From Oxygen in Water.

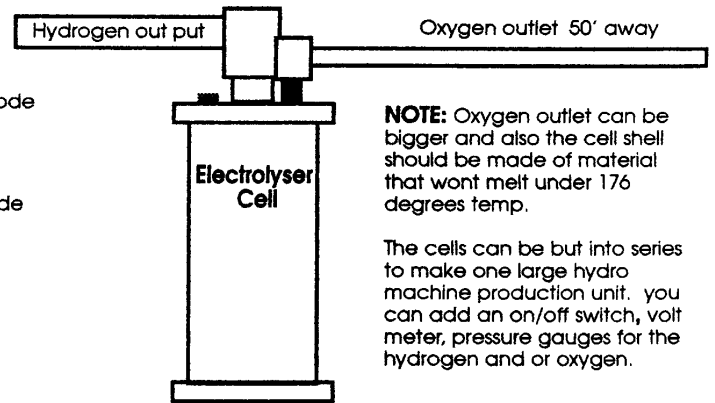
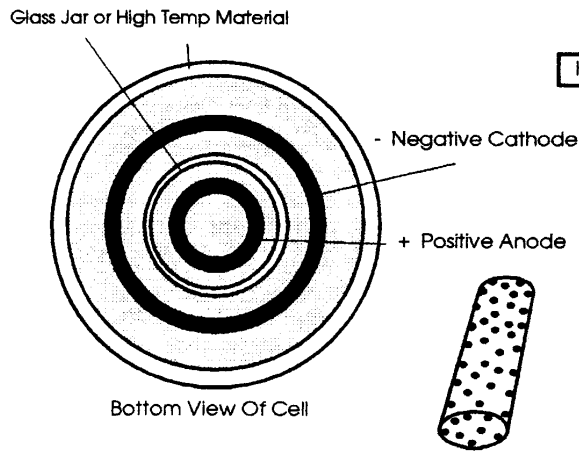
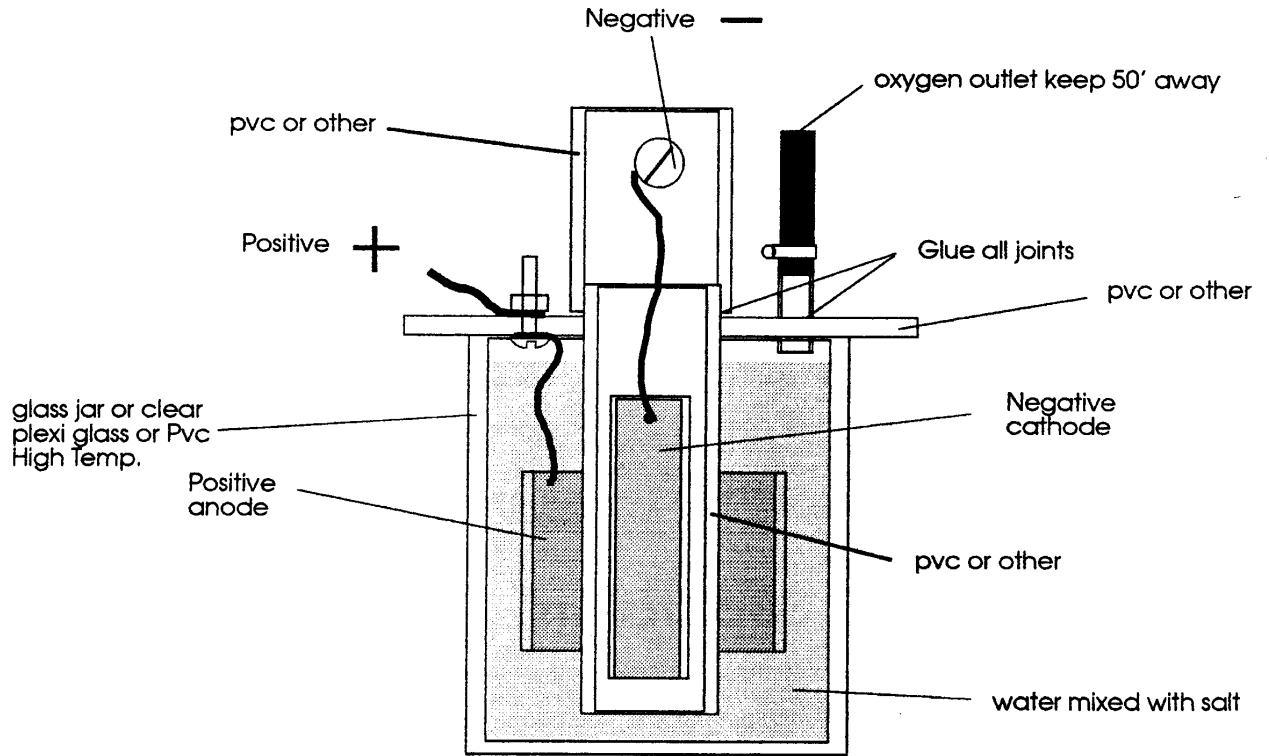

**NOTE:** Oxygen outlet can be bigger and also the cell shell should be made of material that wont melt under 176 degrees temp.

The cells can be but into series to make one large hydro machine production unit. you can add an on/off switch, volt meter, pressure gauges for the hydrogen and or oxygen.

## A WATER-FUELLED CAR

**BY CARL CELIA**

I am the madman behind the US heavy-metal band, "Rampage", but long before my musical success I was mechanically inclined, and the possibility of running a car on fuel extracted from water intrigued me no end.

After reading all the information I could find on the subject of hydrogen generators, I built my first actual unit in 1983, mounting it in the trunk of a 1979 Cadillac Coupe de Ville.

I constructed my system from the best of all the other systems I read about, and then went even further, using the strongest materials and cleanest layout possible within reason. All the titanium nuts and bolts were scored from an aircraft salvage supply: they're cheaper, used, and since they'll never wear out that's one way to save some big bucks. Certain head and exhaust system modifications have to be made to expect trouble-free extended use. For one, the combustion of hydrogen results in the rebonding of the previously-separated hydrogen and oxygen molecules, making the engine's exhaust water vapour steam, and nothing else-meaning absolutely no pollution at all!

Most auto-makers use cast-iron exhaust manifolds and steel valves. The combined effects of heat and moisture (moisture not being present in the combustion of petroleum-based fuels) cause extremely rapid corrosion of the system. Part of the fix is to install stainless-steel valves and an exhaust system constructed entirely out of stainless steel. Racing shops sell stainless-steel valves and stainless-steel 'turbo' mufflers that all work fine. Since hydrogen does not contain lead as some gasoline does, if you're not using a late-model, no-lead engine, the heads will have to be reworked to include valve seats not needing the lubrication lead provides.

As for building this device to sell as a completed system, that's a dead issue. In 1983, I contacted the Department of Energy to show them that my car actually worked. I was confronted by two very belligerent 'agents of tyrannical oppression' who told me that if I tried to sell pre-built units, I'd have a lot of "problems". I asked why, demanding an explanation, and was told very bluntly, and not in a very nice tone: "Do you have any idea what a device like this, available to the public, would do to the economy?"

This technology is so simple that anyone with over half a brain-and knowledgeable in auto mechanics can build one of these units. I've included comprehensive, no-bullshit, drafted design layouts, parts lists, maintenance

tips, and a whole lot of engine modification concepts to make construction, part fabrication and implementation as easy as reasonably possible.

The unit I built works as great as I claim it to, but I offer only the printed information on how to build your own, and I take no personal responsibility for damage of any kind caused to your vehicle or self. (See schematics on following pages.) I have only applied my unit to a carburetted engine; I've never attempted an application to a fuel-injected engine, nor do I make any such claim that an application of that type would be easily performed, if possible at all. *Every cubic foot of water contains about 1,376 cubic feet of hydrogen gas and 680 cubic feet of oxygen.* Because there is no pollution produced, all smog devices may be completely removed, legally, and your car exempted from smog checks, as are propane-powered vehicles.

The only maintenance I've encountered is, periodically, to wire-brush mineral deposits off the reaction chamber electrodes and, at longer intervals, to clean out the chamber itself-*neither of which is complicated or very time-consuming.* I've incorporated so many backup electrodes so this job won't be required roadside-as it was for me when I first used only one, not knowing about any deposits entirely covering the electrodes and thus halting the electrical reaction process. When the car dies out, you just flip another switch until you're somewhere able to brush the reactor's electrodes clean in reasonable comfort -- and not northbound on Highway 5, halfway between Los Angeles and San Francisco, where my first breakdown was.

Where the steel gasoline tank used to be, a plastic water tank is fitted, along with an electric float sensor that should be attached to the vehicle's existing fuel gauge. If you were to start your engine with no modifications other than the carburettor to accept hydrogen fuel, it will run fine but the exhaust system will corrode in almost no time, and if you leave the engine turned off for an extended period, your stock valves and guides will rust up and seize!

Stainless-steel valves don't cost much and are as trouble-free as the stainless-steel exhaust system, so don't be a fool and try to go cheap because you'll only cause yourself added expense and headaches, and you'll be cursing me for your own stupidity. For the cast-iron combustion chambers and valve ports, there is a high-temperature ceramic coating called "heanium" that can be preformed to guard against the same corrosion that affects the valves, guides, exhaust system and also the intake manifold, as moisture down there will also cause corrosion.

Petroleum-based fuels have their own detergent action that protects against corrosion, much like soaking parts in oil prevents corrosion. When using hydrogen as an internal combustion engine fuel, extra precautions must be taken to make extended operation a reality, and not some drive-a-few-thousand-miles-between-fried-engines bullshit.

Don't use sea water! It contains approximately three-fourths of a pound of salt in every gallon. Salt is a material that will coat the electrodes very quickly, just making one big mess. The reason for electrode deposit buildup is that tap water is never 100 percent pure: it contains mineral contaminants that are drawn to the reaction-chamber electrode during the electrically-activated molecular separation process, that results in the hydrogen contained in water being released from the oxygen molecules they are bonded to, making a fuel that can power an internal combustion engine.

I offer no design for an exhaust steam condenser, but I do make the suggestion that one applicable to an automobile can be built to increase the cost-free mileage even further between fill-ups. A concept would include some form of exhaust-fed radiator that could incorporate air ducts, leading from scoops, to direct highway speed airflow across it.

I offer the idea, but not the design, because many aspects must be considered, such as: the least amount of back pressure, unit pressure; unit placement with regard to configuration by the limit or abundance of that space - though this one would be constructed for a stationary, engine-powered electrical generator, where space limitation is of no concern.

Remember, the cylinder walls are cast iron and prone to rust, but they can be kept clean by piston action (as long as it's not left sitting for long periods between use).

An automobile engine could feasibly be constructed with non-corrosive stainless-steel heads and cylinders straight from the factory -- a solid reason to justify spending twenty-five grand or more for a car, because the fuel to run it would be free.

There has been much criticism over hydrogen as an auto fuel, most of it coming straight from those who have the most to lose if hydrogen ever achieves widespread use as an automotive fuel.

There are some factory-built high-performance cars on the market that already come with stainless-steel valves, but they are few and far between, and you still have to change the exhaust systems.

For the carburettor to accept a vapour-state fuel, it must be converted using the same parts that are used in propane/butane engine fuel systems, such as carburettor kits by "Impco", or similar, that do the same thing, i.e., enable your engine to be powered by a vapour-state fuel.

Because no pollution is produced, the engine may be rebuilt 'legally' with higher performance parts, like a camshaft that, on gasoline, would have increased exhaust pollutant emissions, thus making it 'illegal' for highway use. Of course, it's only a 'crime' if you get 'caught', but those pay-again-every-time-your-vehicle-fails smog checks are a pain in the ass, not to mention the wallet.

A similar type of mechanism that opens and closes retractable headlights could be implemented in a dashboard switch-activated system that could open a trunk lid-mounted scoop that captures rain, with a flexible hose line that directs it into the main tank, either while the vehicle is in motion or parked. Just watch the fuel gauge, and close the scoop when you see "Full"!

While it may be a long time before we are able to purchase an entirely corrosion-resistant, exotic alloy engine, I am offering the complete design for a hydrogen generator that will power a car-but any engine modifications I outline are only given as basic concepts. It's up to you to implement what is applicable to your particular engine. Use some initiative. Don't rely on whether I wrote it or not. If you discover a part or a process that I haven't mentioned, that will in any way protect your engine further from the effects of corrosion, use it! I've written this to help people wake up from the big lie of having to depend on oil companies just to drive a car.

Building as many units as I can for personal use only, and writing this booklet, are about the only things I can 'legally' do to try to help the world wake up. A hydrogen generator produces an energy potential in excess of 100 per cent efficiency!!! You read it right: free energy!

A car's battery starts the engine, but once it's running, the alternator takes over to charge the battery and power the ignition system. With an onboard hydrogen generator, that alternator also powers the hydrogen extraction process, producing the energy needed to fuel the engine that runs the alternator. No external power source is needed; so as long as there is water available, the entire system is self-sufficient in operation. An extra trunk-mounted battery would provide more current-if ever needed-to run everything at once without overloading the electrical system.

### **System Operation**

The dash-mounted switches for turning on the reactor are also wired to activate the chamber feedwater pump at the same time. When the car dies out, that signals to you that an electrode has been totally crusted over with deposits from the impure fuel water. This means the electrically-activated molecular separation process (electrolysis) has halted. These switches should also have indicator lights to let you know which one is on, and flip-up caps to guard against accidental activation.

When the need arises to go to backup, turn off the switch for the 'dead' electrode, as well as close its electrical shut-off valve. The purpose of these gas valves is to keep pressurised oxygen from escaping up through the 'off' electrode fittings into the hydrogen lines, possibly resulting in your car becoming a "Highway Hindenburg"!

Hydrogen is separated from its molecular bond with oxygen by exposing the fluid of water to direct-current voltage. Hydrogen is attracted to a negative charge, while oxygen is attracted to a positive charge. This process generates heat in the chamber, so trunk placement is best with an aluminium or plywood wall built between the reactor and the rest of the available trunk space. Small cars are light on gasoline, thus cheaper to operate, but when all of a sudden the fuel becomes free, the size and weight of the car is of no concern, except for Porsches and similar sportscars, street rods, etc.

Water is pumped through the reaction chamber, which itself is positively charged, drawing the oxygen molecules out through the water return-line to be vented off through the water tank's cap. The hydrogen-attracting electrode extending into the welded-in pipes (and insulated under the T-fitting) is negatively charged. There is a dash-mounted pressure gauge that is connected before the regulator and mixer. To begin hydrogen generation, flip one of the dash-mounted switches and wait for the gauge to show fuel-line pressure; then start the engine when pressure is shown by the gauge to exist. In mounting the unit, remember that the chamber itself is positive, and most cars use a negative chassis ground, so insulated mounts must be fabricated between the positive chamber and the negative trunk-floor.

As a final note, this unit is not a concept or a theory! It is tried and proven! I designed this system at age 18 in 1983, and built more than one, using Rampage profits for research and development . I can't sell actual working units, but nothing but death itself can stop me from distributing this information in the hope that people will take the initiative to wake up from the big lie of oil-dependency for auto fuel, and flood the street with hydrogen-powered cars.

If enough people find out how simple it is, public pressure may someday soon be put on the government, resulting in the long overdue media exposure they're all so afraid of. *Eyewitness News* (Channel 7) in Los Angeles didn't want to let the word out that an actual working vehicle had been built by an 18-year-old metalhead! We're supposed to be stupid in the public's eye, from their point of view!

Hydrogen and oxygen gases do not pollute; they help clean out carbon deposits from the engine for better mileage and less engine wear. You'll notice the improved engine performance immediately.

**Source: Carl Cella, P0 Box 8101 (4176-X), San Luis Obispo, CA 93409-0001, USA.**

**Do-It-Yourself Special Feature: MODIFY YOUR CAR TO "BURN" WATER! - - Technical Diagrams (reproduced exactly as we received them)**

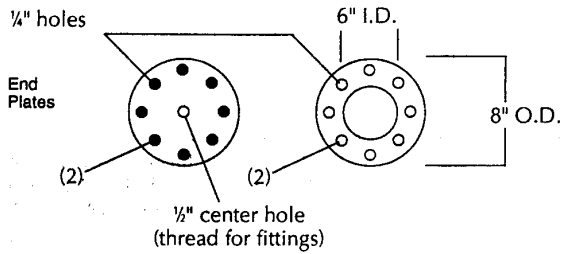
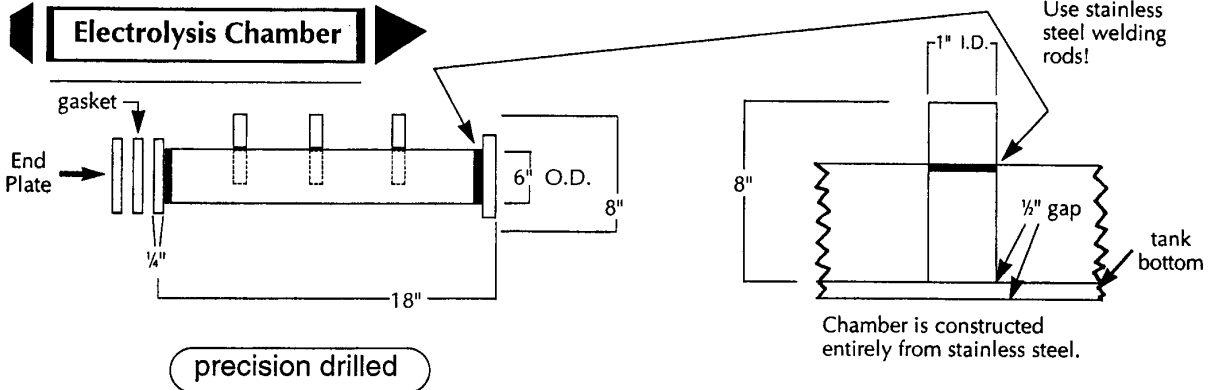

- Get the materials listed below!**
- (1) 18" x 6" O.D. x 1/8" stainless steel pipe
  - (3) 8" x 1" I.D. x 1/8" stainless steel pipes
  - (2) 8" O.D. x 6" I.D. x 1/4" end flanges
  - (2) 8" x 1/4" end plates
  - (16) 1" x 1/4" aircraft salvaged titanium bolts
  - (16) 1/4" aircraft salvaged titanium self-locking nuts
- For the vapor fuel conversion parts:  
(fuel mixer, and low pressure regulator)  
IMPCO CARBURETION  
16916 Gridley Plaza  
Cerritos, CA 90701 USA

**HERE'S How:**

**Hydrogen Electrode Fabrication (Exploded View)**

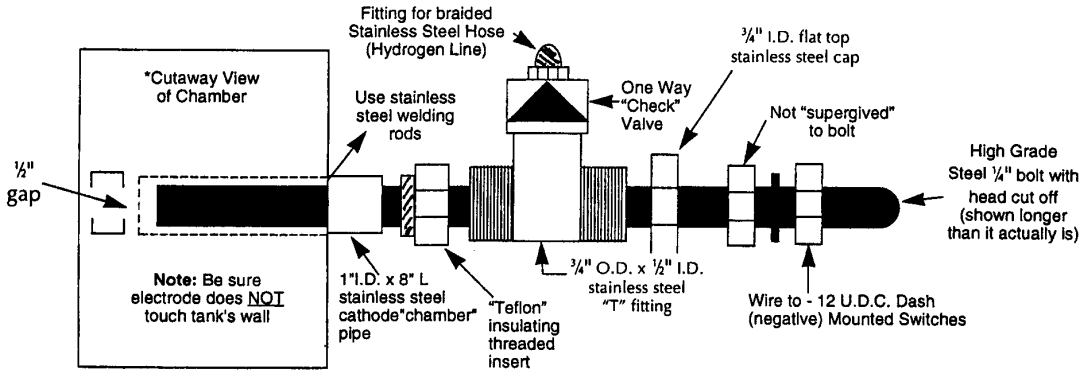

Hydrogen burns slightly hotter than gasoline

- KEY:**
- O.D. = Outside Diameter
  - I.D. = Inside Diameter
  - V.D.C. = Voltage Direct Current

### HYDROGEN GENERATOR INSTALLATION

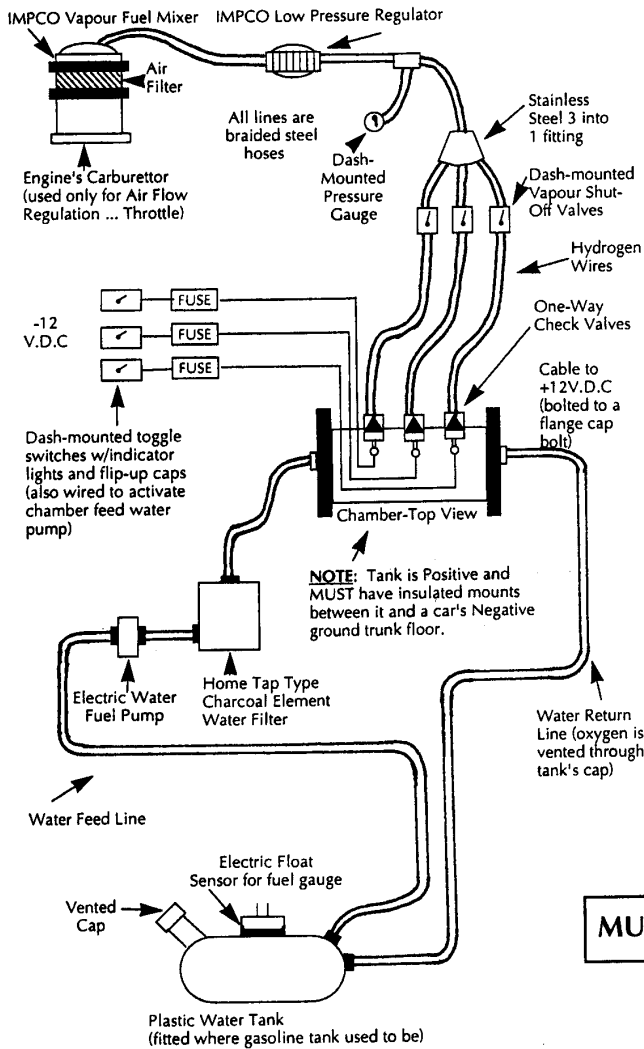

### GENERAL PARTS:

- Stainless Steel Valves
- Bronze Valve Guides
- Stainless Steel Piston Rings
- Stainless Steel Headers
- Stainless Steel Mufflers
- Stainless Steel Exhaust Tubing

'Teflon' Core Braided Steel Hose (Buy a roll - you'll need a lot!)

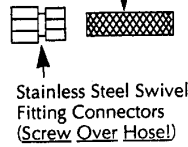

- \* Stainless Steel Dual Exhaust System (Headers)
- \* Electric Muffler Drain/Water Recovery Pump fed back into Main Tank ("T"-fitting between both stainless steel turbo mufflers using heat-proof braided steel hose)

**NOTE:** The combustion of hydrogen results in the reformation of water. The engine's exhaust is water vapour **steam**. Some of this **steam** condenses into water, collecting inside the mufflers. This system recovers the water content of these mufflers.

### MUFFLER WATER RECOVERY SYSTEM CONCEPT

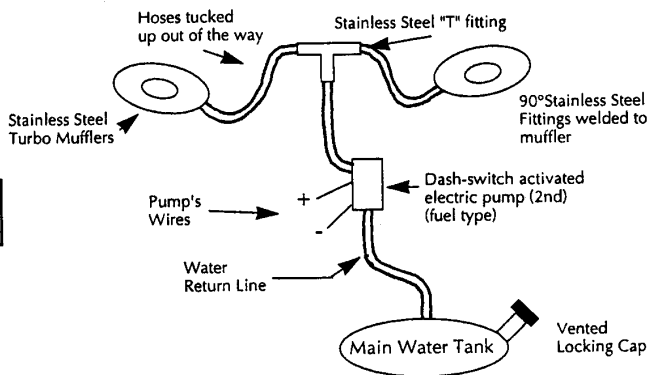

### CHAMBER MOUNTING IN CAR'S TRUNK

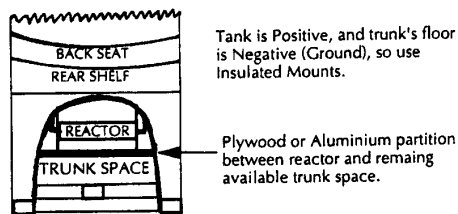



## FUEL FOR FREE - HYDROGEN GENERATOR

BY CARL CELLA, 1983

### COMMENTARY BY BYRON PECK, 1989

*NOTE: While this report may be someone redundant to one above, it is included since it contains some additional insight.*

*Even though Carl Celia claims to have installed several of his hydrogen systems on automobiles and fuelling them solely on water over the highways of California in 1983, we make this document available as information only and can make no claims as to the viability of the system or to the validity of the claims made by Carl Celia.*

*Carl originally wrote FUEL FOR FREE in 1983 and shortly thereafter went to prison on a murder conviction. Between that time and 1988, he remained silent about the hydrogen system. In 1988, Carl began to write and publish FUEL FOR FREE from his prison cell with the help of friends on the outside.*

*During that five year period Carl admits he forgot a number of details pertaining to construction of the system. Certain components and processes are no longer available.*

*Everyone knows that vehicles can be fueled with hydrogen. The big argument right now is whether Carl's system can accomplish this.*

*FUEL FOR FREE is presented as information only and food for thought. New ideas are the only way progress is made and this is easily verified with a simple study in history.*

*This is the February 1990 edition of FUEL FOR FREE.*

*- Byron Peck*

### Introduction

First of all, this is not a hypothetical energy system, it's real and has been road tested.

Carl Celia says he is the madman behind the heavy metal band "RAMPAGE", but long before his musical success, he was very active in mechanics and the possibility of feasibly running a car on fuel extracted out of water intrigued him to no end.

Carl continues, "after reading all the information I could find on the subject of hydrogen generators, I built my first actual unit in 1983, mounting it in the trunk of a 1979 Cadillac Coupe de Ville."

"You don't have to worry about gas mileage, because gross vehicle weight is of no concern when the fuel you're using is free! I constructed my system from the best aspects of all the other systems I read about, then went even further to also use the strongest materials and cleanest layout possible within reason."

"All the titanium nuts and bolts were obtained from an aircraft salvage supply; they're cheaper used and since they'll never wear out, that's a way to save some big bucks. Certain head and exhaust system modifications have to be made for trouble free extended operation."

"For one, the combustion of hydrogen results in the re-bonding of the previously separated hydrogen and oxygen molecules, making the engine's exhaust water vapor steam and nothing else, meaning absolutely no pollution at all! Most automakers use cast iron exhaust manifolds and steel valves. The combined effects of heat and moisture (moisture not being present in the combustion of petroleum based fuels) cause extremely rapid corrosion of the valves, exhaust manifolds and muffler system."

"Part of the fix is to install stainless steel valves, stainless steel exhaust headers and stainless steel "turbo" mufflers. Since hydrogen does not contain lead as some gasoline does, if you're not using a late model no-lead engine, the heads will have to be reworked to include valve seats not needing the lubrication that lead provides."

For Carl, building this device to sell as a completed system became a dead issue in 1983. His confrontation with the Department of Energy is not an isolated incident.

"I contacted the Department of Energy to show them that my car actually worked; I was confronted by two very belligerent agents of tyrannical oppression," who told me if I tried to sell pre-built units, you'd have a lot of "problems." I asked why, and was very bluntly told in a harsh tone: "Do you have any idea what a device like this available to the public would do to the economy?"

"It all boils down to big money; oil company revenues and gasoline taxes. The world oil supply is very regulated, and profitable to make as scarce as "legally" possible to keep prices high. How can they control water? There are still many sources of free unregulated water!" Unless there is a super shortage of water they can't make any money off it."

"This technology is so simple, that anyone with over half a brain and knowledgeable in automotive mechanics can build one of these units. I've included comprehensive no-bullshit drafted design layouts, parts lists,

maintenance tips, and a whole lot of engine modification concepts to make construction, part fabrication, and implementation as easy as reasonably possible."

"The unit I built works as good or better than claimed, but all I can do is offer printed information on how to build your own. I take no personal responsibility nor does the publisher for damage of any kind caused to your vehicle or any person caused as a result of failure follow the instructions and follow general mechanical common sense. I have written the instructions in as plain English as possible."

"I have only applied my unit to engines with carburetors. I have never applied my unit to an engine with fuel injection nor do I recommend that you try to do so."

"Because there is no pollution produced, all smog devices may be completely removed legally. Your car will be exempted from smog checks, as are propane powered vehicles. The only maintenance I've ever encountered is to periodically use a wire brush to remove mineral deposits from the reaction chamber electrodes, and at longer intervals, clean out the chamber itself; neither of which is complicated or very time consuming.

I've incorporated so many back-up electrodes so this job won't be one you have to do on the shoulder of the freeway as it was for me when at first I used only one, not knowing about deposits covering the entire electrode, thus halting the electrical reaction process."

"When the car dies out, just flip another switch, and so on until you are somewhere able to brush the reactor's electrodes clean in reasonable comfort; and not northbound on Interstate 5, halfway between Los Angeles and San Francisco where my first "breakdown" was. Where the steel gasoline tank used to be, a plastic water tank is fitted, along with an electrical float sensor that will be attached to the vehicle's existing fuel gauge."

"If you were to start your engine with no modifications other than the carburetor to accept hydrogen fuel, it will run fine, but the exhaust system will rapidly corrode in almost no time, and if you leave the engine turned off for a very brief "extended period," your stock valves and guides will rust up and seize!"

"Stainless steel valves don't cost much, and are as trouble free as the stainless steel exhaust system; so don't be a fool and try to go cheap, because you'll only cause yourself added expense, headaches, and you'll be cursing me out for your own stupidity."

"For the cast iron combustion chambers and valve ports, there is high temperature ceramic coating called "HEANIUM" that can be formed to guard against the same corrosion that affects the valves, guides and exhaust system.

Also consider protecting the runners of the intake manifold; moisture down there too will cause corrosion."

"Petroleum based fuels have their own detergent action that protects against corrosion, much like soaking parts in oil prevents corrosion. When using hydrogen as an internal combustion engine fuel, extra precautions must be taken to make extended operation a reality, and not some drive a few thousand miles between "fried" engines as the result of not doing a thorough conversion."

"Don't use seawater!!!!!! It contains approximately three fourths of pound of salt in every gallon; a material that will coat the electrodes very quickly, just making one big mess."

"The reason for the electrode deposit build-up is that tap water is never 100% pure. It contains mineral contaminants that are drawn to the reaction chamber electrode during the electrically activated molecular separation process that results in the hydrogen contained in water to be released from the oxygen molecules they are bonded to; making a fuel that can power an internal combustion engine."

"The two most abundant elements in the Universe are hydrogen and stupidity; hydrogen can easily be produced in a controllable form from water; and stupidity will either mis-apply it when exposed to the technology behind it, or just plain keep it suppressed out of easily seen public view for personal gain by pushing upon people, who don't know otherwise, the costly, and environmentally deteriorative auto fuel gasoline, of which the price and supply can be completely manipulated by the parasitic energy cartels."

"The two biggest money makers on earth are the electric and oil companies. If the un-informed consumers only knew how simple hydrogen generation is, nobody would buy gasoline!!! And, electricity can be generated by engine powered devices, and those, engines can be fueled by hydrogen."

"Now back to the engine. The cylinder walls are cast iron and prone to rust, but those are kept clean by piston action (as long as its not left sitting for long periods between use), though an entire engine built from stainless steel would be the hot ticket; don't hold your breath for the big guys in Detroit or Japan to offer anything that will make hydrogen powered cars readily available. They're making money on gasoline."

"How much do you spend a year on gasoline? How much time do you waste watching television, which is mostly lies anyway? Now get your outside and spend that time and money converting your car to run on hydrogen."

"I don't know' about you, but with a world food crisis knocking at the front door I'd rather have resources for food rather than worry about gasoline. Wouldn't it be more logical to be able to spend more on a nicer car with the money saved on not having to buy gasoline?"

"For the carburetor to accept a vapor state fuel, it must be converted using the same parts that are used in propane/butane engine fuel systems; such as carburetor kits by "IMPCO," or similar to that, that do the same thing (enable your engine to be powered by a vapor state fuel). Because no pollution is produced, the engine may "legally" be rebuilt with higher performance parts, like a camshaft that on gasoline would have increased exhaust pollutant emissions; thus making it "illegal" for highway use."

"With hydrogen powering everybody's car, who would have the most to lose? BIG BAD BROTHER and the Bankers, that's who. No more gasoline taxes, smog certification fees, failure to comply fines for disconnect'ed smog devices, extra charges for those devices on the car's purchase price, gas stations on every corner, smog alerts, ozone depletion, or being stranded roadside at midnight miles from anywhere during a rainstorm out of gas!!!!"

"A type of mechanism 'similar to which opens and close retractable headlights could be implemented in a dash switch activated system that could open a trunk lid mounte'd scoop that captures rain, with a flexible hose line that directs it into the main tank; either while the vehicle is in motion or parked. Just watch the fuel guage, and close the scoop when you see full!"

"While it may be a long time before we are able to purchase an entirely corrosion resistant exotic alloy engine factory direct) there still a lot that can be done to reasonable compensate for the effects of a water derived fuel on an internal combustion engine."

"I am givying you here the fully complete design for a hydrogen generator that will run your car or truck, but any engine modifications I outline are only given as basic concepts; it's up to you to implement what is applicable to your particular engine. Use some initiative. Don't rely on whether I wrote it or not; if you discover a part, or a process that I haven't mentioned that will in any way protect your engine further from the effects of corrosion, use it!!!!!"

"I've written this booklet to help people wake up from the big lie of having to depend on oil companies just to drive a car. If a city's buses were powered by hydrogen, they would have no grounds for charging a buck or more for fare, citing rising fuel costs as a factor."

"If you're wondering why, if this works, it isn't being used by a lot of people. There is no money to be made by the oil companies as I already told you; Big money corrupts Small minds!!!! And then we our society filled with people who seem to only be here for the purpose of being nemesises for everybody creative....by saying things like: "Oh, I don't believe that," or, "That doesn't really work, it's just a hoax, ,I saw a guy on TV that showed how that stuff burns up engines." Over 95% of the people that comprise the general public have been brainwashed all their lives to believe everything they see on television as the undisputed truth!!!"

"I drove my car down to the Los Angeles, office of the channel seven eyewitness news to show them a car that actually work, telling them if they run stories on the negative mistakes people have made in attempting construction of 'a hydrogen' powered car, why not run a story on a car that has all the bugs worked out, that actually functions! All I got was double talk about how "people just don't care about hearing this type of stuff." Television is a major force behind the big lie mass public brainwashing."

"Government wants everyone to believe that everything has to cost money. Not only are they worried about losing money on hydrogen powered transportation vehicles, they have a major concern over hydrogen powered engines that could be used to run generators for virtually every home in the world. The water company would be the only public utility (outside of telephones, of course) in mass demand."

### **System Operation**

"The dash mounted switches for turning on the reactor are also wired to activate the chamber feed water pump at the same time. When the car dies out, that signals you to that an electrode has been totally crusted over with deposits from the impure fuel water."

"This means the electrically activated molecular separation process (electrolysis) has halted. These switches should also have indicator lights to let you know which one is on, and flip-on caps to guard against accidental activation. When the need arises to go to back-up, turn off the switch for the dead electrode, as well as close its vapor shut-off valve. Now switch on a back-up electrode, and open its shut-off valve."

"The purpose of these gas valves is to keep pressurized oxygen from scaping up through the off electrode fittings into the hydrogen line, possibly resulting in your car becoming a Highway Hindenburg!!! Hydrogen is separated from its molecular bond with oxygen with exposing the fluid of water to direct current voltage."

"Hydrogen is attracted to a negative charge, while oxygen is attracted to a positive charge. This process generates heat in the chamber, to trunk placement is best with an aluminum or plywood wall built between the reactor and the rest of the available trunk space. Small cars are light on gasoline, thus cheaper to operate, but when all of a sudden the fuel becomes free, the size and weight of the car is of no concern."

"Except for the Porsche and similar sports cars, street rods, etc., who the hell likes being crammed like a sardine in a rolling in coffin? Agility may be sacrificed for those into "quick" cars, but cadillacs will do 130 mph for very long distances; try that in a Yugo, and chances are you'll be in HELL before I will!!!!!"

"Water is pumped through the reaction chamber, and the chamber itself is positively charged, drawing the oxygen molecules out through the water return line to be vented off through the water tank's cap. The hydrogen attracting electrode extending (insulated under the T fitting) into the welded in pipes is negatively charged."

"There is a dash mounted pressure gauge that is connected before the regulator and mixer. To begin hydrogen generation, flip one of the dash mounted switches, and wait for the gauge to show fuel line pressure, then, start engine when pressure is shown by the gauge to exist. In mounting the unit, remember that the chamber itself is positive, and most cars use a negative chassis ground, so insulated mounts must be fabricated between the positive chamber and the negative trunk floor."

"Final Note: This unit is NOT a concept or a theory! It is tested, tried and proven on the road! I designed and built this system at age 18 in 1983, and built more than one using profits from "Rampage" for research and development."

"I can't sell actual working units from inside this prison cell, but nothing will stop the distribution of this booklet in the hopes that people will take initiative to wake-up from the big lie of oil dependency for auto fuel, and flood the streets with hydrogen powered cars."

"Eyewitness News in L.A. didn't want to let the word out that an actual working vehicle had been built by an 18 year old metalhead! We're supposed to be stupid in the public's eye from their point of view, and that just really sucks!!!

- Carl Cella

The following are recently submitted comments in Carl Cella's own to clarify certain areas of his originally published FUEL FOR FREE.

The Impco regulator has a pressure relief vent line that I just routed under the car.

The "negative" is a 3/4" stainless steel bar stock rod that is lathe turned down (with a 1/2" taper between the two O.D.'s) to 1/4" to fit up through the T fitting. It is held in place by drilling a hole in a thick stainless steel flat top hex cap, that's threaded to allow the electrode to be screwed up in there, and is jammed by the superglued nut.

Sure I used a tube of "sealer" to stop any potential leaks. Don't use 3-M three bond, or you'll never get it back apart without damage, just use a good 3-M HIGH TEMPERATURE fast drying silicone type and goo it all around the threaded parts as you install them. Don't use that 24 hour drying time stuff, use the fast drying stuff.

What I labelled as dash mounted vapor shut off valves should really be the same kind of electrically activated SOLENOID VALVES that are used for racing systems of nitrous oxide! Only the switches are dash mounted, and my sketches were drawn FREEHAND, and could be a lot better.

Experiment with the smallest possible chamber size and diameter. However, the system that I have illustrated is what I built and ran my cars on.

The welded in pipe has a 1" I.D., the negative electrode SHOULD REALLY be made of 3/4" stainless steel round stock, lathe turned down at one end for a few inches to 1/4" to fit up through the teflon insert; and T fitting, so the gap between the negative electrode and pipe wall is only 1/8".

The "mixer" I used was a 300A, I forgot the number for their low pressure regulator, just something with a vent line to allow excess hydrogen to escape into the atmosphere.

If your pressure regulator doesn't have a vent line, it's just going to push hydrogen back into the chamber, ALSO resulting in lower hydrogen production.

I've never heard of Moly-Disulphide, but it would be fine if it's comparable to Heanium. Heanium is used for corrosion protection; it's used in racing engines for heat protection. The man's name (I think) is Heany, and Hot Rod magazine may have his shop's address. It's a high temperature ceramic type coating, but it's like microscopic in thickness.

For the benefit of the skeptics, 12 volts fries this water, and does produce enough hydrogen to run a car, in fact more than enough!

Nobody can say it won't work until after they have built it according to specification.

It is also recommended to install stainless steel rings in your engine.

If you have any other questions, you may consult with Carl directly. Just write to him and include a self-addressed stamped envelope. You'll find him very sincere--and eager to help you.

Carl Cella D-22706

Box 8101 (4176-X)

San Luis Obispo, CA 93409-0001

*What Carl did not take into account when he wrote this paper is the drought and the fact that it was probably created by man using sophisticated weather control technology.*

*The drought is expected to continue for several years. If fresh water becomes a rare commodity we can always use the technology of Albert Aul in patent number 3,474,014 for the electrogravitational desalination of sea water.*